



**UTENSILIOS DE COCINA /  
KITCHEN UTENSILS /  
USTENSILES DE CUISINE /  
KÜCHENUTENSILIEN**

- 5.1** **UTENSILIOS DE COCINA / KITCHEN UTENSILS /  
USTENSILES DE CUISINE / KÜCHENUTENSILIEN** **94**
- 5.2** **PROCESADORES MANUALES DE ALIMENTOS /  
MANUAL FOOD PROCESSORS /  
APPAREILS MANUELS DE TRANSFORMATION DES ALIMENTS /  
HANDLICHEN SCHNEIDEMASCHINEN GEEIGNET FÜR** **121**
- 5.3** **TABLAS DE CORTE / CUTTING BOARDS /  
PLANCHES À DÉCOUPER / SCHNEIDBRETTER** **136**
- 5.4** **ELEMENTOS DE MEDIDA / MEASURING UTENSILS /  
USTENSILES DE MESURE / MESSUTENSILIEN** **139**
- 5.5** **MANOPLA / MITT / GAN / HANDSCHUHE** **143**
- 5.6** **ALFOMBRAS CAUCHO / NATURAL RUBBER MATS /  
TAPIS EN CAOUTCHOUC / KAUSCHUKMATTEN** **143**

**5.1** UTENSILIOS DE COCINA / KITCHEN UTENSILS /  
USTENSILES DE CUISINE / KÜCHENUTENSILIEN

**Cacillo monobloc /**  
*One piece ladle /*

**P3011** Louche monobloc /  
*Monoblock Schöpflöffel*

**Capacidad marcada en el mango /**  
*Capacity marked on the handle /*  
*Capacité marqué à la queue /*  
*Volumenangabe am Griff markiert*



| REF      | Ø cm | L cm | Lts  | €/u   | 📦  |
|----------|------|------|------|-------|----|
| P301.165 | 6,5  | 31   | 0,07 | 8,20  | 12 |
| P301.108 | 8    | 32   | 0,13 | 9,10  | 12 |
| P301.109 | 9    | 33   | 0,20 | 10,15 | 12 |
| P301.110 | 10   | 37   | 0,25 | 11,10 | 6  |
| P301.112 | 12   | 42   | 0,45 | 12,95 | 6  |
| P301.114 | 14   | 43   | 0,75 | 16,40 | 6  |
| P301.116 | 16   | 45   | 1,00 | 17,35 | 6  |
| P301.118 | 18   | 48   | 1,50 | 26,90 | 6  |

**Cacillo para salsas con 2 picos laterales /**  
*One piece sauce ladle with 2 spouts /*

**P392** Cuillère à sauces monobloc avec 2 becs verseurs /  
*Schöpflöffel für Sossen mit 2 seitlichen Ausgüssen*

**Capacidad marcada en el mango /**  
*Capacity marked on the handle /*  
*Capacité marqué à la queue /*  
*Volumenangabe am Griff markiert*

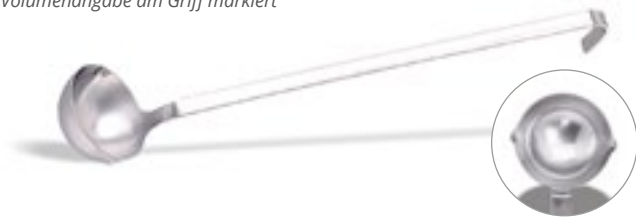

| REF      | Ø cm | L cm | Lts  | €/u   | 📦  |
|----------|------|------|------|-------|----|
| P392.065 | 6,5  | 31   | 0,08 | 11,90 | 10 |

**4980120** **Cacillo monobloc Kool-Touch® / One-Piece ladle Kool-Touch® handle /**  
*Louche monobloc manche Kool-Touch® / Monoblock Schöpflöffel Kool-Touch® Griffen*



| REF     | Color  | Ø cm | L cm | ml  | €/u   | 📦  |
|---------|--------|------|------|-----|-------|----|
| 4980120 | Black  | 4,5  | 25,0 | 30  | 13,70 | 12 |
| 4980230 | Blue   | 6,0  | 25,0 | 60  | 15,85 | 12 |
| 4980335 | Yellow | 7,5  | 32,0 | 90  | 18,80 | 12 |
| 4980445 | Grey   | 8,5  | 32,0 | 120 | 19,75 | 12 |
| 4980655 | Teal   | 9,0  | 31,5 | 175 | 21,55 | 12 |
| 4980865 | Orange | 10,0 | 32,0 | 235 | 22,35 | 12 |

**82 °C** **Revestimiento mango / Coated handle /**  
*Revêtement queue / Griffbeschichtung*

UTENSILIOS DE COCINA / KITCHEN UTENSILS /  
USTENSILES DE CUISINE / KÜCHENUTENSILIEN

**Cacillo monobloc económico /**  
*Economical one piece ladle /*

**P3012** Louche monobloc économique /  
*Monoblock Schöpflöffel ökonomisch*

**Capacidad marcada en el mango /**  
*Capacity marked on the handle /*  
*Capacité marqué à la queue /*  
*Volumenangabe am Griff markiert*



| REF      | Ø cm | L cm | Lts  | €/u   | 📦  |
|----------|------|------|------|-------|----|
| P301.206 | 6    | 27   | 0,05 | 5,20  | 10 |
| P301.208 | 8    | 31   | 0,12 | 7,00  | 10 |
| P301.210 | 10   | 33   | 0,25 | 8,65  | 10 |
| P301.212 | 12   | 36   | 0,42 | 10,30 | 10 |
| P301.214 | 14   | 39   | 0,75 | 12,90 | 10 |
| P301.216 | 16   | 43   | 1,20 | 15,65 | 10 |

**Cacillo monobloc mango corto /**  
*One piece ladle short handle /*

**P30326** Louche monobloc manche court /  
*Monoblock Schöpflöffel kurzer Stiel*

**Capacidad marcada en el mango /**  
*Capacity marked on the handle /*  
*Capacité marqué à la queue /*  
*Volumenangabe am Griff markiert*



| REF      | Ø cm | L cm | Lts  | €/u   | 📦  |
|----------|------|------|------|-------|----|
| P303.265 | 6,5  | 22   | 0,07 | 10,15 | 10 |

UTENSILIOS DE COCINA / KITCHEN UTENSILS /  
USTENSILES DE CUISINE / KÜCHENUTENSILIEN

**Espumadera monobloc /**  
*One piece skimmer /*

**P3021** Écumoire monobloc /  
*Schaumlöffel Monoblock*



| REF      | Ø cm | L cm | €/u   | 📦  |
|----------|------|------|-------|----|
| P302.108 | 8    | 29   | 7,80  | 10 |
| P302.110 | 10   | 32   | 9,25  | 10 |
| P302.112 | 12   | 35   | 9,90  | 10 |
| P302.114 | 14   | 37   | 12,65 | 10 |
| P302.116 | 16   | 44   | 13,80 | 5  |
| P302.118 | 18   | 44   | 21,50 | 5  |
| P302.120 | 20   | 47   | 26,20 | 5  |

**Espátula monobloc sin perforar /**  
*One piece spatula /*

**P3141** Spatule monobloc /  
*Pfannenwender Monoblock*



| REF      | Ø cm | L cm | €/u   | 📦 |
|----------|------|------|-------|---|
| P314.110 | 10   | 36   | 11,05 | 5 |
| P314.112 | 12   | 39   | 11,85 | 5 |

**Pala pescado monobloc /**  
*One piece fish spatula /*

**P3143** Pelle à poisson monobloc /  
*Fischwender Monoblock*



| REF      | cm      | L cm | €/u   | 📦 |
|----------|---------|------|-------|---|
| P314.300 | 16 x 12 | 42   | 15,20 | 5 |

UTENSILIOS DE COCINA / KITCHEN UTENSILS /  
USTENSILES DE CUISINE / KÜCHENUTENSILIEN

**Espumadera monobloc económica /**  
*Economical one piece skimmer /*

**P3022** Écumoire monobloc économique /  
*Schaumlöffel Monoblock ökonomisch*



| REF      | Ø cm | L cm | €/u   | 📦  |
|----------|------|------|-------|----|
| P302.210 | 10   | 33   | 7,50  | 10 |
| P302.212 | 12   | 36   | 8,50  | 10 |
| P302.214 | 14   | 39   | 10,65 | 10 |
| P302.216 | 16   | 42   | 11,90 | 10 |

**Espátula monobloc perforada /**  
*One piece perforated spatula /*

**P3142** Spatule monobloc perforée /  
*Gelochter Pfannenwender Monoblock*



| REF      | Ø cm | L cm | €/u   | 📦 |
|----------|------|------|-------|---|
| P314.210 | 10   | 36   | 11,55 | 5 |
| P314.212 | 12   | 39   | 12,05 | 5 |

**Espumadera de alambre /**  
*Mesh skimmer /*

**P315** Écumoire à friture /  
*Drahtschaumlöffel*



| REF      | Ø cm | L cm | €/u   | 📦  |
|----------|------|------|-------|----|
| P315.010 | 10   | 40   | 10,40 | 10 |
| P315.012 | 12   | 43   | 13,65 | 10 |
| P315.015 | 15   | 50   | 18,70 | 10 |
| P315.017 | 17   | 54   | 22,15 | 10 |
| P315.020 | 20   | 61,5 | 27,00 | 10 |

**P94101** Araña / Wire skimmer /  
Araignée / Schaumlöffel



| REF      | Ø cm | L cm | €/u   | 📦  |
|----------|------|------|-------|----|
| P941.013 | 13   | 47,5 | 9,35  | 10 |
| P941.015 | 15   | 49,5 | 10,50 | 10 |
| P941.018 | 18   | 52,5 | 11,35 | 10 |
| P941.020 | 20   | 54,5 | 13,25 | 10 |
| P941.022 | 22   | 67,0 | 14,55 | 5  |
| P941.024 | 24   | 69,0 | 15,60 | 5  |
| P941.028 | 28   | 69,0 | 17,55 | 5  |

**P394** Molde nido / Bird nest mould /  
Moule à nid / Vogelnestform

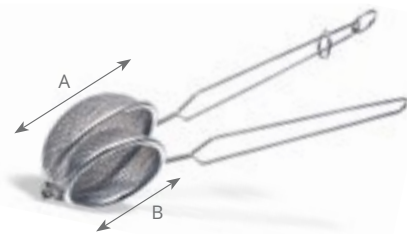

| REF      | Ø A cm | Ø B cm | €/u   | 📦 |
|----------|--------|--------|-------|---|
| P394.008 | 10     | 8      | 17,60 | 1 |
| P394.012 | 12     | 10     | 20,80 | 1 |

**P3761**  
Cuchara honda monobloc profesional /  
Professional one piece deep spoon /  
Cuillère profonde monobloc professionnelle /  
Tiefer professioneller Löffel Monoblock



| REF      | Ø cm | €/u   | 📦  |
|----------|------|-------|----|
| P376.137 | 37   | 10,65 | 10 |

**P955** Espumadera malla fina / Mesh skimmer /  
Écumoire maillée / Feiner Drahtschaumlöffel



Detalle de la malla a escala real  
Detail of the sieve at real scale  
Détail de la maille à échelle réelle  
Detail Maschen in realer Größe

| REF      | Ø cm | L cm | €/u   | 📦  |
|----------|------|------|-------|----|
| P955.010 | 10   | 40   | 6,75  | 10 |
| P955.012 | 12   | 43   | 9,00  | 10 |
| P955.015 | 15   | 50   | 10,70 | 10 |
| P955.017 | 17   | 54   | 16,00 | 10 |
| P955.020 | 20   | 61   | 18,35 | 10 |

**P376** Cuchara monobloc profesional /  
Professional one piece spoon /  
Cuillère monobloc professionnelle /  
Professioneller Löffel Monoblock



| REF      | Ø cm | €/u   | 📦  |
|----------|------|-------|----|
| P376.037 | 37   | 10,55 | 10 |

**P377**  
Cuchara perforada monobloc profesional /  
Professional one piece perforated spoon /  
Cuillère perforée monobloc professionnelle /  
Gelochter professioneller Löffel Monoblock



| REF      | Ø cm | €/u   | 📦  |
|----------|------|-------|----|
| P377.037 | 37   | 10,70 | 10 |

**P3771**  
Cuchara honda monobloc profesional perforada /  
Professional one piece perforated deep spoon /  
Cuillère profonde monobloc professionnelle perforée /  
Tiefer gelochter professioneller Löffel Monoblock



| REF      | Ø cm | €/u   | 📦  |
|----------|------|-------|----|
| P377.137 | 37   | 10,70 | 10 |

**64130** Cuchara / Solid spoons /  
Cuillères pleines / Massiv Löffel



232 °C

| REF     | Color  | L cm | €/u   | 📦  |
|---------|--------|------|-------|----|
| 64130   | Black  | 35   | 14,30 | 12 |
| 6414015 | White  | 35   | 14,30 | 12 |
| 6414030 | Blue   | 35   | 14,30 | 12 |
| 6414040 | Red    | 35   | 14,30 | 12 |
| 6414050 | Yellow | 35   | 14,30 | 12 |
| 6414070 | Green  | 35   | 14,30 | 12 |

**P3972** Tenedor monobloc /  
One piece meat fork /  
Fourchette monobloc /  
Fleischgabel Monoblock



2 púas / 2 prongs / 2 dents / 2 Zinken

| REF      | Ø cm | €/u   | 📦  |
|----------|------|-------|----|
| P397.247 | 47   | 18,25 | 10 |

**P395**  
Cuchara oblicua monobloc /  
One piece crosswire spoon /  
Cuillère oblique monobloc /  
Sossenlöffel Monoblock



| REF      | L cm | BASE cm | Lts   | €/u   | 📦  |
|----------|------|---------|-------|-------|----|
| P395.038 | 38   | 10 x 7  | 0,075 | 11,25 | 10 |

**64132** Cuchara perforada / Perforated spoons /  
Cuillères perforées / Perforiert Löffel



232 °C

| REF     | Color  | L cm | €/u   | 📦  |
|---------|--------|------|-------|----|
| 64132   | Black  | 35   | 14,30 | 12 |
| 6414215 | White  | 35   | 14,30 | 12 |
| 6414230 | Blue   | 35   | 14,30 | 12 |
| 6414240 | Red    | 35   | 14,30 | 12 |
| 6414250 | Yellow | 35   | 14,30 | 12 |
| 6414270 | Green  | 35   | 14,30 | 12 |

**P3973** Tenedor monobloc /  
One piece meat fork /  
Fourchette monobloc /  
Fleischgabel Monoblock



3 púas / 3 prongs / 3 dents / 3 Zinken

| REF      | L cm | €/u   | 📦  |
|----------|------|-------|----|
| P397.347 | 47   | 19,05 | 10 |

# ANTIMICROBIAL

UTENSILIOS CON PROPIEDADES ANTIMICROBIALES NATURALES /  
UTENSILS WITH NATURE'S ANTIMICROBIAL /  
USTENSILES AVEC TRAITEMENT ANTIMICROBIEN /  
SERVIERTENSILIEN MIT NATUREIGENEM ANTIMIKROBIOTIKUM



No es difícil imaginar la gran cantidad de microbios y microorganismos que se pueden alojar en los mangos de los utensilios de cocina. Vollrath Pujadas lanza una gama de herramientas que evita que éstos se reproduzcan, gracias a la tecnología AGIO, con iones de plata que retienen las bacterias y evitan su reproducción.

It is not difficult to imagine the large number of microbes and micro-organisms that can live on the handles of kitchen utensils. Vollrath Pujadas has launched a range of tools that prevent them from reproducing, thanks to AGIO technology, with silver ions that hold on to the bacteria and prevent them reproducing.

Il n'est pas difficile d'imaginer le grand nombre de microbes et de microorganismes présents sur les manches des ustensiles de cuisine. Vollrath Pujadas lance une gamme d'ustensiles qui empêchent leur reproduction, grâce à la technologie AGIO, aux ions d'argent qui stoppent les bactéries et empêchent leur reproduction.

Es ist nicht schwer, sich die große Anzahl von Mikroben und Mikroorganismen vorzustellen, die sich auf den Griffen von Küchenutensilien befinden. Vollrath Pujadas bringt eine Palette von Küchensubehör heraus, das dank der AGIO-Technologie verhindert, dass sich diese Mikroorganismen vermehren. Silberionen neutralisieren Bakterien und verhindern deren Vermehrung.

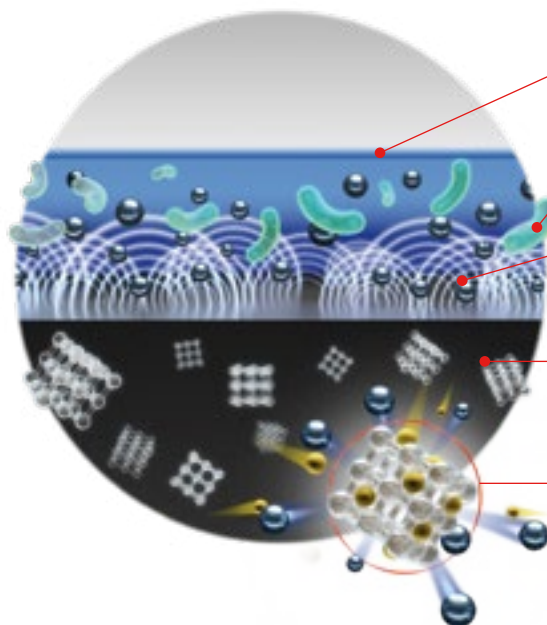

**Película superficial de humedad /**  
Surface film of moisture /  
Film de surface de l'humidité /  
Feuchtigkeitsfilm an der Oberfläche

**Bacteria / Bacteria /**  
Bactéries / Bakterium

**Olas de iones de plata anti-microbianos atacando /**  
Waves of antimicrobial silver ions attacking /  
Ondes d'ions argent anti-microbiens attaquant /  
Angriffswellen antimikrobieller Silber-Ionen

**Material del mango con zeolitas incrustadas /**  
Handle material with embedded antimicrobial zeolites /  
Matériau de manche avec zéolites intégrées /  
Griffmaterial mit eingebetteten Zeolithen

**Zeolitas liberando iones de plata /**  
Antimicrobial zeolite releasing silver ions /  
Zéolites libérant des ions argent /  
Silber-Ionen freisetzende Zeolithe



# SPOODLE®

**Capacidad marcada en el mango /**  
Capacity marked on the handle /  
Capacité marqué à la queue /  
Volumenangabe am Griff markier.



**Mango y porcionadores de acero inoxidable brillante — resistente a la corrosión /**

Mirror-finished stainless steel shafts and bowls — resistant to corrosion /

Tiges et cuillerons en acier inoxydable ultra-brillant — résistant à la corrosion /

Stiel und Höhlungen aus hochglanzpoliertem Edelstahl – gegen Korrosion beständig.

**Mango con diseño ergonómico, de Nylon que reduce la fatiga durante su uso. Max temp 232 °C /**

Handle with ergonomic design, made from nylon which reduces wear during use. Maximum temperature 232 °C /

Manche au design ergonomique en nylon qui réduit la fatigue pendant son emploi. Temp. Max. 232 °C /

Griff mit Ergonomischem Design aus Nylon, was den Verschleiß Während der Nutzung Reduziert. Max. Temp. 232 °C.

| COLOR /<br>COLOR /<br>COULEUR /<br>FARBE | ml  |
|--|-----|
| Blue                                     | 60  |
| Orange                                   | 90  |
| Grey                                     | 120 |
| Teal                                     | 175 |
| Red                                      | 235 |

## 6433230 Spoodle® monobloc redondo / One-Piece Round Spoodle® / Spoodle® monobloc ronde / Monoblok Rundschaalen Spoodle®



232 °C



| REF     | Ø cm | L cm | ml  | €/u   | ☐  |
|---------|------|------|-----|-------|----|
| 6433230 | 6,5  | 32   | 60  | 11,65 | 12 |
| 6433335 | 7,4  | 33   | 90  | 11,65 | 12 |
| 6433445 | 8,2  | 34   | 120 | 12,15 | 12 |
| 6433655 | 9,3  | 35   | 175 | 12,65 | 12 |
| 6433865 | 10,2 | 36   | 235 | 13,05 | 12 |

**5284220** Cuchara nylon / Nylon spoon / Cuillère nylon / Nylonlöffel



| REF     | Color | L cm | €/u  | 📦  |
|---------|-------|------|------|----|
| 5284220 | Black | 34   | 7,85 | 12 |
| 5284320 | Black | 34   | 7,85 | 12 |

**4689760** Cuchara nylon para preparación / Nylon spoon for preparation /  
Cuillère nylon pour préparation / Nylonlöffel für die Zubereitung



| REF     | Color        | L cm | €/u  | 📦  |
|---------|--------------|------|------|----|
| 4689760 | Light Yellow | 21,6 | 5,00 | 12 |
| 4689815 | White        | 30,5 | 5,00 | 12 |
| 4689830 | Blue         | 30,5 | 5,00 | 12 |
| 4689840 | Red          | 30,5 | 5,00 | 12 |
| 4689850 | Yellow       | 30,5 | 5,00 | 12 |
| 4689860 | Light Yellow | 30,5 | 5,00 | 12 |
| 4689960 | Light Yellow | 38,1 | 6,95 | 12 |

**47139** Porcionador / Thumb disher / Cuillère de service / Portionierer



| REF   | Color  | Tamaño /<br>Size | Ø mm | Mlts  | €/u   | 📦  |
|-------|--------|------------------|------|-------|-------|----|
| 47139 | White  | 6                | 76   | 157,7 | 15,20 | 12 |
| 47140 | White  | 8                | 73   | 118,3 | 15,20 | 12 |
| 47141 | White  | 10               | 70   | 96,1  | 15,20 | 12 |
| 47142 | Green  | 12               | 64   | 78,9  | 15,20 | 12 |
| 47143 | Blue   | 16               | 57   | 59,1  | 15,20 | 12 |
| 47144 | Yellow | 20               | 52   | 48,1  | 15,20 | 12 |
| 47145 | Red    | 24               | 48   | 39,4  | 15,20 | 12 |
| 47146 | Black  | 30               | 44   | 29,6  | 15,20 | 12 |

**47390** Porcionador apretable / Squeeze disher / Cuillère-pression de service / Eisportionierer



| REF   | Color  | Tamaño /<br>Size | Ø mm | Mlts | €/u   | 📦  |
|-------|--------|------------------|------|------|-------|----|
| 47390 | White  | 6                | 76   | 139  | 19,80 | 12 |
| 47391 | White  | 8                | 73   | 110  | 19,80 | 12 |
| 47392 | White  | 10               | 70   | 96   | 19,80 | 12 |
| 47393 | Green  | 12               | 64   | 84   | 19,80 | 12 |
| 47395 | Blue   | 16               | 57   | 59   | 19,80 | 12 |
| 47396 | Yellow | 20               | 52   | 53   | 19,80 | 12 |
| 47397 | Red    | 24               | 48   | 45   | 19,80 | 12 |
| 47398 | Black  | 30               | 44   | 33   | 19,80 | 12 |
| 47399 | White  | 36               | 44   | 28   | 19,80 | 12 |
| 47403 | Black  | 70               | 32   | 14   | 19,80 | 12 |

Ver productos en / See products on / Voir produits en page / Siehe produkte in

P. 152

ESPÁTULA SILICONA ALTA TEMPERATURA /  
HIGH HEAT SILICONE SPATULA. BOWL SCRAPER /  
SPATULE SILICONE HAUTE TEMPÉRATURE /  
SILIKONSPACHTEL HOHE TEMPERATUREN



**P34001** Cacillo /  
Ladle /  
Louche /  
Schöpflöffel

Nylon



| REF      | L cm | Lts  | €/u  | 📦  |
|----------|------|------|------|----|
| P340.010 | 28,5 | 0,08 | 2,40 | 12 |

**P34002** Espumadera /  
Skimmer /  
Écumoire /  
Schaumlöffel

Nylon



| REF      | L cm | Ø cm | €/u  | 📦  |
|----------|------|------|------|----|
| P340.020 | 27   | 10,7 | 2,40 | 12 |

**P34003** Cuchara de servicio /  
Serving spoon /  
Cuillère de service /  
Servierlöffel

Nylon



| REF      | L cm | €/u  | 📦  |
|----------|------|------|----|
| P340.030 | 27,5 | 2,40 | 12 |

**P34004** Espátula /  
Turner /  
Spatule /  
Pfannenwender

Nylon



| REF      | L cm | €/u  | 📦  |
|----------|------|------|----|
| P340.040 | 28,5 | 2,40 | 12 |

**P34005** Espátula wok /  
Wok spatula /  
Spatule wok /  
Wokspachtel

Nylon



| REF      | L cm | €/u  | 📦  |
|----------|------|------|----|
| P340.050 | 27,5 | 2,40 | 12 |

**P34006** Espátula pastelera /  
Baker spatula /  
Palette /  
Kuchenheber

Nylon



| REF      | L cm | €/u  | 📦  |
|----------|------|------|----|
| P340.060 | 29   | 2,40 | 12 |

**P34007** Cuchara espagueti /  
Spaghetti server /  
Cuillère à spaghetti /  
Spaghettilöffel

Nylon



| REF      | L cm | €/u  | 📦  |
|----------|------|------|----|
| P340.070 | 29   | 2,40 | 12 |

**P34008** Tenedor /  
Meat fork /  
Fourchette /  
Fleischgabel

Nylon



| REF      | L cm | €/u  | 📦  |
|----------|------|------|----|
| P340.080 | 29,5 | 2,40 | 12 |

**P34009** Pinza /  
Tong /  
Pince /  
Zange

Nylon



| REF      | L cm | €/u  | 📦  |
|----------|------|------|----|
| P340.090 | 30,5 | 2,40 | 12 |



INOX - ST/STEEL  
EDELSTAHL  
18/10

**IDEA!** Pinzas ideales para emplatar y decorar  
Plating tongs for careful lifting, turning and decorating  
Pincas idéales pour la présentation et la décoration  
Ideale Zangen Zum Anrichten und Dekorieren

**P3434** Pinza chef precisión extra larga (fina) / Extra long fine tip straight tweezer (narrow) /  
Pince du chef précision extra long (étroite) / Extra lange Präzisionspinzette (schmal)



| REF      | L cm | €/u   |   |
|----------|------|-------|---|
| P343.400 | 30   | 10,75 | 1 |

**P3436** Pinza chef precisión / Fine tip straight tweezer / Pince du chef précision / Präzisionspinzette



| REF      | L cm | €/u  |   |
|----------|------|------|---|
| P343.600 | 21   | 5,80 | 1 |

**P3437** Pinza Chef precisión pequeña / Small fine tip straight tweezer /  
Pince du chef précision petite / Kleine Präzisionspinzette

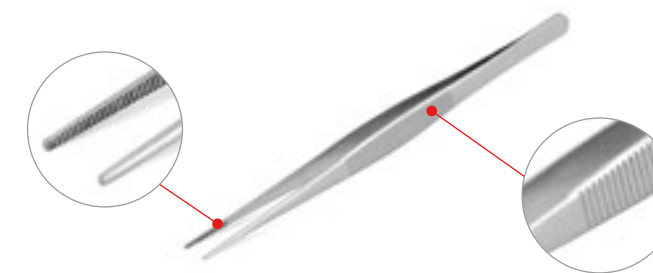

| REF      | L cm | €/u  |   |
|----------|------|------|---|
| P343.700 | 16   | 3,65 | 1 |

**P3438** Pinza sushi / Sushi tweezer / Pince à sushi / Sushipinzette

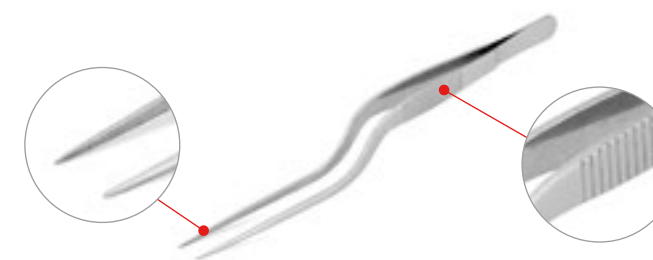

| REF      | L cm | €/u  |   |
|----------|------|------|---|
| P343.800 | 16   | 4,75 | 1 |

Ver productos en / See products on / Voir produits en page / Siehe produkte in

P.  
166

**ARO REDONDO PARA TARTA /**  
ICE CREAM CAKE RING /  
CERCLE À VACHERIN /  
RUNDER TORTENRING



5.1 UTENSILIOS DE COCINA / KITCHEN UTENSILS / USTENSILES DE CUISINE / KÜCHENUTENSILIEN

UTENSILIOS DE COCINA / KITCHEN UTENSILS / USTENSILES DE CUISINE / KÜCHENUTENSILIEN



**P358 INOX** Pinza buffet / Utility tong / Pince buffet / Buffetzange



| REF      | L cm | €/u  | 📦  |
|----------|------|------|----|
| P358.024 | 24,0 | 4,25 | 12 |
| P358.029 | 29,5 | 4,85 | 12 |
| P358.040 | 40,0 | 6,25 | 12 |

**P358 COLOR** Pinza buffet inox mango color / St. steel utility tong coloured handle / Pince buffet inox manche couleur / Rostfreie Buffetzange mit farbigem Griff



| REF  | L cm | Blanco / White / Blanc / Weiss | Rojo / Red / Rouge / Rot | Azul / Blue / Bleu / Blau | Amarillo / Yellow / Jaune / Gelb | Verde / Green / Vert / Grün | Marrón / Brown / Marron / Braun | Negro / Black / Noir / Schwarz | €/u  | 📦 |
|------|------|--------------------------------|--------------------------|---------------------------|----------------------------------|-----------------------------|---------------------------------|--------------------------------|------|---|
| P358 | 24   | 1                              | 2                        | 3                         | 4                                | 5                           | 6                               | 7                              | 6,05 | 1 |
| P358 | 30   | 1                              | 2                        | 3                         | 4                                | 5                           | 6                               | 7                              | 6,70 | 1 |
| P358 | 40   | -                              | -                        | -                         | 4                                | -                           | -                               | 7                              | 8,50 | 1 |

Ref : P358 + L + Color / Colour / Couleur / Farbe

Fabricadas en acero inoxidable monobloc. Mango con revestimiento PVC aislante para una mejor sujeción /

Made of one piece St/Steel. Handle with PVC coating for a better grip and insulation /

Fabriquéés en acier inoxydable monobloc. Manche avec revêtement PVC pour une meilleure préhension et isolation /

Hergestellt aus rostfreien Monoblock. Griff mit PVC Beschichtung für bessere Griffigkeit und Isolierung.

UTENSILIOS DE COCINA / KITCHEN UTENSILS / USTENSILES DE CUISINE / KÜCHENUTENSILIEN

UTENSILIOS DE COCINA / KITCHEN UTENSILS / USTENSILES DE CUISINE / KÜCHENUTENSILIEN



Fabricadas en acero inox, de una sola pieza, en forma de W que aseguran una máxima resistencia y durabilidad.

Made of a single piece of stainless steel, in a W form to ensure maximum resistance and durability.

Fabriquéés en acier inox, en une seule pièce, en forme de W, garantissant une résistance et une durabilité maximums.

Aus rostfreiem Stahl, einteilig, in W-Form, was maximale Widerstandskraft und Langlebigkeit garantiert.



**4780920** Pinza buffet monobloc Kool-Touch® / One-Piece utility tong Kool-Touch® / Pince buffet Kool-Touch® / Einteilige, farblich gekennzeichnete Kool-Touch® gewellter Servierzangen

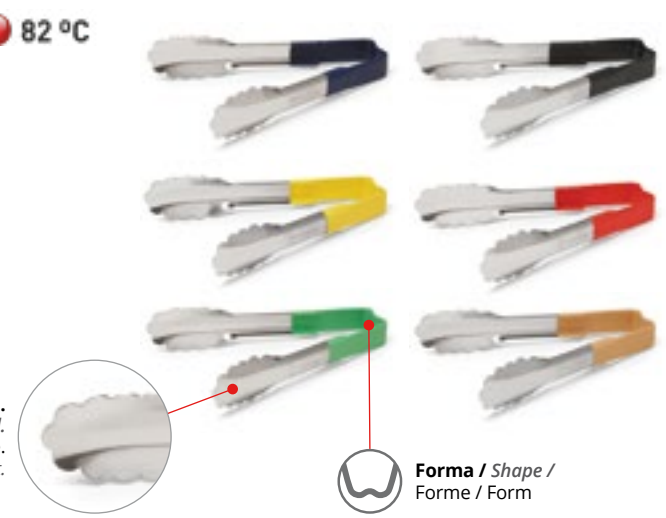

| REF     | Color  | L cm | €/u   | 📦  |
|---------|--------|------|-------|----|
| 4780920 | Black  | 24   | 11,30 | 12 |
| 4781220 | Black  | 30   | 11,90 | 12 |
| 4781620 | Black  | 40   | 14,80 | 12 |
| 4780930 | Blue   | 24   | 11,30 | 12 |
| 4781230 | Blue   | 30   | 11,90 | 12 |
| 4781630 | Blue   | 40   | 14,80 | 12 |
| 4780940 | Red    | 24   | 11,30 | 12 |
| 4781240 | Red    | 30   | 11,90 | 12 |
| 4781640 | Red    | 40   | 14,80 | 12 |
| 4780950 | Yellow | 24   | 11,30 | 12 |
| 4781250 | Yellow | 30   | 11,90 | 12 |
| 4781650 | Yellow | 40   | 14,80 | 12 |
| 4780960 | Orange | 24   | 11,30 | 12 |
| 4781260 | Orange | 30   | 11,90 | 12 |
| 4781660 | Orange | 40   | 14,80 | 12 |
| 4780970 | Green  | 24   | 11,30 | 12 |
| 4781270 | Green  | 30   | 11,90 | 12 |
| 4781670 | Green  | 40   | 14,80 | 12 |

Festoneada. Scalloped. Festonné. Gewellt.

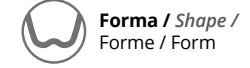

**4780620** Pinza buffet monobloc Kool-Touch® / One-Piece tong Kool-Touch® / Pince buffet inox Kool-Touch® / Rostfreie Buffetzange Kool-Touch®

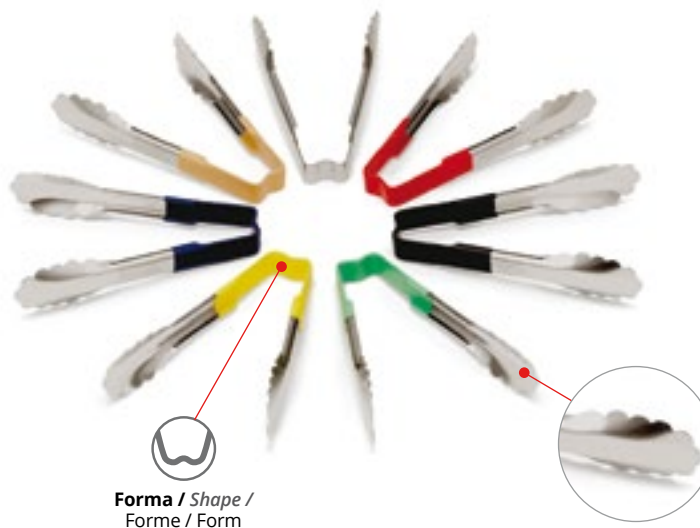

| REF     | Color  | L cm | €/u  | 📦  |
|---------|--------|------|------|----|
| 4780620 | Black  | 15   | 8,65 | 12 |
| 4780630 | Blue   | 15   | 8,65 | 12 |
| 4780640 | Red    | 15   | 8,65 | 12 |
| 4780650 | Yellow | 15   | 8,65 | 12 |
| 4780660 | Orange | 15   | 8,65 | 12 |
| 4780670 | Green  | 15   | 8,65 | 12 |

Pinza más corta para espacios estrechos o comida delicada / Shorter utility tong for tight spaces or delicate food applications /

Pince utilitaire courte pour espaces restreints ou aliments délicats à manipuler /

Kürzere Universalzange für beengte Platzverhältnisse und das Arbeiten mit delikaten Speisen

Festoneada. Scalloped. Festonné. Gewellt.

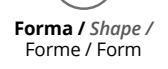

**4780912** Pinza con extremo de nylon / Utility tong with nylon end /  
Pince utilitaire avec extrémité nylon / Universalzange mit Nylonenden

NSF 232 °C



Festoneada.  
Scalloped.  
Festonné.  
Gewellt.

Forma / Shape /  
Forme / Form

| REF     | L cm | €/u   |    |
|---------|------|-------|----|
| 4780912 | 24   | 16,65 | 12 |
| 4781212 | 30   | 17,85 | 12 |

Inox + Nylon / St/Steel + Nylon /  
Rostfreier Stahl + Nylon

**4780610** Pinza de acero inoxidable / Stainless steel tong / Pince inoxydable / Edelstahl-Servierzange

NSF

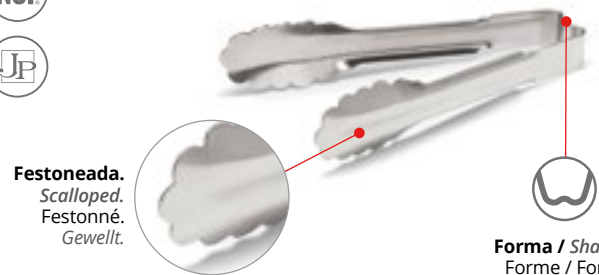

Festoneada.  
Scalloped.  
Festonné.  
Gewellt.

Forma / Shape /  
Forme / Form

| REF      | L cm | €/u   |    |
|----------|------|-------|----|
| 4780610* | 15,2 | 6,60  | 12 |
| 4780910  | 24,1 | 8,35  | 12 |
| 4781210  | 30,5 | 8,65  | 12 |
| 4781610  | 40,6 | 10,85 | 12 |

\* Pinza mas corta para espacios estrechos o comida delicada /  
\* Shorter utility tong for tight spaces or delicate food applications /  
\* Pince utilitaire courte pour espaces restreints ou aliments deli-  
cats a manipuler /  
\* Kürzere Universalzange für beengte Platzverhältnisse und das Arbei-  
ten mit delikaten Speisen

**4791210** Pinza VERSAGRIP® de acero inoxidable / VERSAGRIP® Stainless steel tong /  
Pince inox VERSAGRIP® / VERSAGRIP® Edelstahl-Servierzange

NSF

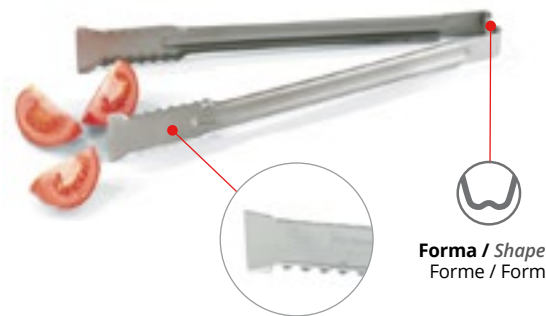

Forma / Shape /  
Forme / Form

| REF     | L cm | €/u   |    |
|---------|------|-------|----|
| 4791210 | 30,5 | 8,65  | 12 |
| 4791610 | 40,6 | 10,75 | 12 |

VERSAGRIP®  
Presenta extremos aplanados y dentados para mayor agarre.  
Features flattened ends and gripper teeth.  
Offre des extrémités aplaties et crantées pour une meilleure prise.  
Mit abgeflachten Enden und gezahntem Greifer.

**47046** Pinza dentada reforzada / Reinforced Pom Tong /  
Pince ceinture renforcée / Verstärkte Gezahnte Zange

NSF



| REF   | L cm | €/u  |    |
|-------|------|------|----|
| 47046 | 15,2 | 3,95 | 36 |
| 47049 | 22,9 | 5,60 | 24 |

INOX - ST/STEEL  
EDELSTAHL

Construcción de una sola pieza / One-piece construction /  
Construction monobloc / Einteilige Ausführung

Ideal para hornos, brasa y barbacoa  
Ideal for ovens, grills and barbecues  
Idéal pour fours, grill et barbecue  
Ideal für Öfen, Kohlenfeuer und Grillanlagen

**47326** Pinza dentada reforzada Kool-Touch® /  
Kool-Touch® Reinforced Pom Tong /  
Pince ceinture renforcée Kool-Touch® /  
Kool-Touch® Verstärkte Gezahnte Zange

NSF 82 °C



INOX - ST/STEEL  
EDELSTAHL

Construcción de una sola pieza / One-piece construction /  
Construction monobloc / Einteilige Ausführung

Ideal para hornos, brasa y barbacoa  
Ideal for ovens, grills and barbecues  
Idéal pour fours, grill et barbecue  
Ideal für Öfen, Kohlenfeuer und Grillanlagen

| REF   | L cm | €/u  |    |
|-------|------|------|----|
| 47326 | 15,2 | 8,05 | 12 |

**47325** Pinza tipo tijeras de uso intensivo /  
Heavy-Duty scissor tongs /  
Pinces type ciseaux à usage intensif /  
Schere zange für starke Beanspruchung



| REF   | Color | L cm | €/u   |    |
|-------|-------|------|-------|----|
| 47325 |       | 38   | 18,60 | 12 |

**P620** Pala chips / Chip bagger /  
Pelle à frites / Frittenschaufel



Mano derecha / Right hand  
Main droite / Rechtshändig

| REF      | cm      | €/u   |   |
|----------|---------|-------|---|
| P620.001 | 23 x 21 | 20,40 | 1 |

**P611** Pinza dentada / Pom tong /  
Pince ceinture / Gezahnte Zange



Ideal para hornos, brasa y barbacoa  
Ideal for ovens, grills and barbecues  
Idéal pour fours, grill et barbecue  
Ideal für Öfen, Kohlenfeuer und Grillanlagen

| REF      | L cm | €/u  |    |
|----------|------|------|----|
| P611.001 | 24   | 2,00 | 24 |

**P851004** Pinza horno extra reforzada /  
Heavy duty oven tong /  
Pince renforcée four /  
Verstärkte Zange für Öfen

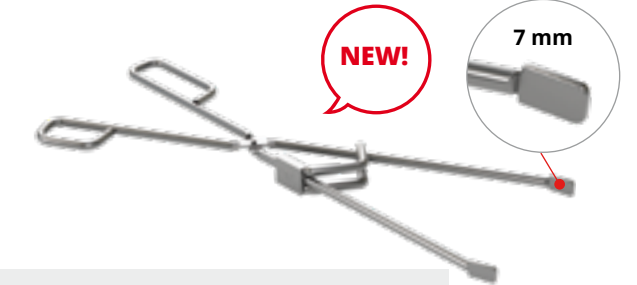

Ideal para hornos, brasa y barbacoa  
Ideal for ovens, grills and barbecues  
Idéal pour fours, grill et barbecue  
Ideal für Öfen, Kohlenfeuer und Grillanlagen

| REF      | L cm | €/u   |    |
|----------|------|-------|----|
| P851.004 | 40   | 35,00 | 12 |

**P621** Pala chips ABS / ABS chip bagger /  
Pelle à frites en ABS / Frittenschaufel ABS

+ 80 °C



| REF      | cm      | €/u  |   |
|----------|---------|------|---|
| P621.000 | 23 x 21 | 5,35 | 1 |



**5.1** UTENSILIOS DE COCINA / KITCHEN UTENSILS /  
USTENSILES DE CUISINE / KÜCHENUTENSILIEN

**Espátula lisa, biselada /**  
*Solid, beveled turner with /*  
*Palette pleine, biseautée /*  
*Pfannenwender für schwere*  
**4808720** *Beanspruchung Griffen massiv abgeschragt*



Extra resistente /  
Heavy duty /  
Extra résistant /  
Extra-resistent



| REF     | Color | (L x W) cm | L cm | €/u   | 📦  |
|---------|-------|------------|------|-------|----|
| 4808720 | Black | 15 x 7,5   | 34,5 | 12,25 | 12 |
| 4808715 | White | 15 x 7,5   | 34,5 | 12,25 | 12 |

**Espátula perforada reforzada /**  
*Perforated Turner with /*  
*Palette perforée renforcée /*  
*Edelstahl-Pfannenwender für*  
**4808920** *schwere Beanspruchung perforiert*



Extra resistente /  
Heavy duty /  
Extra résistant /  
Extra-resistent



| REF     | Color | (L x W) cm | L cm | €/u   | 📦  |
|---------|-------|------------|------|-------|----|
| 4808920 | Black | 21 x 7,5   | 42   | 12,15 | 12 |

UTENSILIOS DE COCINA / KITCHEN UTENSILS /  
USTENSILES DE CUISINE / KÜCHENUTENSILIEN

**Espátula reforzada /**  
*Solid Turner /*  
*Palette renforcée /*  
*Edelstahl-Pfannenwender für schwere*  
**4808820** *Beanspruchung massiv*



Extra resistente /  
Heavy duty /  
Extra résistant /  
Extra-resistent



| REF     | Color | (L x W) cm | L cm | €/u   | 📦  |
|---------|-------|------------|------|-------|----|
| 4808820 | Black | 21 x 7,5   | 42   | 12,15 | 12 |

**Espátula nylon reforzada /**  
*Slotted reinforced nylon turner /*  
*Spatule renforcée à nylon /*  
*Hochtemperaturbeständiger*  
**5284120** *Nylon-Pfannenwender,*  
*Geschlitzter Wender*



Extra resistente /  
Heavy duty /  
Extra résistant /  
Extra-resistent



**Construcción de una sola pieza /**  
*One-piece construction /*  
*Construction monobloc /*  
*Einteilige Ausführung*

| REF     | Color | L cm | €/u  | 📦  |
|---------|-------|------|------|----|
| 5284120 | Black | 34,5 | 8,65 | 12 |

UTENSILIOS DE COCINA / KITCHEN UTENSILS /  
USTENSILES DE CUISINE / KÜCHENUTENSILIEN

**Espátula triangular "pintor" /**  
*Cleaning spatula / Palette triangle /*  
**P381** *Dreieckige Reinigungsspachtel*

Mango ABS / ABS Handle /  
Manche en ABS / ABS Griff



| REF      | cm | L cm | €/u  | 📦  |
|----------|----|------|------|----|
| P381.008 | 8  | 24,5 | 5,00 | 12 |
| P381.010 | 10 | 25   | 5,25 | 12 |

**Pala fast-food y pescado /**  
*Fast-food and fish turner /*  
*Palette fast-food et poisson /*  
**P383** *Fast-Food und Fischschaufel*

Mango ABS / ABS Handle /  
Manche en ABS / ABS Griff

Flexible /  
Flexibel



| REF      | cm       | L cm | €/u  | 📦  |
|----------|----------|------|------|----|
| P383.000 | 7,3 x 25 | 38   | 8,10 | 12 |

**Rasqueta / Dough scraper /**  
**P386** *Raclette / Schaber*

Mango ABS / ABS Handle /  
Manche en ABS / ABS Griff



| REF      | cm       | €/u  | 📦  |
|----------|----------|------|----|
| P386.000 | 15 x 7,5 | 4,35 | 12 |

**P385** **Espátula pastelera / Baker spatula /** *Palette / Kuchenspachtel*

Mango ABS / ABS Handle /  
Manche en ABS / ABS Griff



**P382** **Pala bar / Spatula /** *Palette / Spachtel*

Mango ABS / ABS Handle /  
Manche en ABS / ABS Griff



| REF      | cm     | L cm | €/u  | 📦  |
|----------|--------|------|------|----|
| P382.000 | 7 x 16 | 29   | 6,85 | 12 |

**Pala fast-food perforada /**  
*Perforated fast-food turner /*  
**P384** *Palette fast-food perforée /*  
*Fast-Food Schaufel gelocht*

Mango ABS / ABS Handle /  
Manche en ABS / ABS Griff

Flexible /  
Flexibel



| REF      | cm       | L cm | €/u  | 📦  |
|----------|----------|------|------|----|
| P384.000 | 7,3 x 25 | 38   | 8,20 | 12 |

**P380** **Ruleta cortapizzas / Pizza wheel /** *Roulette à pizza / Pizzaschneider*

Mango ABS / ABS Handle /  
Manche en ABS / ABS Griff



| REF      | cm | L cm | €/u  | 📦  |
|----------|----|------|------|----|
| P380.000 | 10 | 23,5 | 5,15 | 12 |

| REF      | Pala / Peel /<br>Pelle / Blatt<br>cm | L cm | €/u  | 📦  |
|----------|--------------------------------------|------|------|----|
| P385.020 | 20,5                                 | 34   | 5,95 | 12 |
| P385.026 | 26                                   | 39   | 6,50 | 12 |
| P385.030 | 30                                   | 43,5 | 6,85 | 12 |

**Espátula para untar /**  
*Butter spreader /*  
Couteau à beurre /  
*Aufstrichspachtel*

**P3855**



| REF      | Pala / Peel /<br>Pelle / Blatt<br>cm | L cm | €/u  |    |
|----------|--------------------------------------|------|------|----|
| P385.500 | 10,4 x 3,4                           | 23   | 2,10 | 12 |

**Rasqueta triangular. Mango madera /**  
*Triangle dough scraper. Wood handle /*  
Raclette triangle. Manche en bois /  
*Dreieckiger Schaber. Holzgriff*

**P37501**



| REF      | Pala / Peel /<br>Pelle / Blatt<br>cm | L cm | €/u  |    |
|----------|--------------------------------------|------|------|----|
| P375.010 | 10,2 x 10                            | 21   | 4,35 | 12 |

**Rasqueta rectangular. Mango madera /**  
*Rectangular dough scraper. Wood handle /*  
Raclette rectangle. Manche en bois /  
*Rechteckiger Schaber. Holzgriff*

**P37507**



| REF      | Pala / Peel /<br>Pelle / Blatt<br>cm | L cm | €/u  |    |
|----------|--------------------------------------|------|------|----|
| P375.070 | 15,2 x 7,6                           | 11,3 | 3,35 | 12 |

**Pala pasteles /**  
*Cake server /*  
Pelle à gâteau /  
*Keksschaufel*

**P872**

**Sin sierra /**  
*Without saw /*  
Sans scie /  
*Ohne säge*



| REF      | L cm | €/u  |    |
|----------|------|------|----|
| P872.000 | 28   | 3,35 | 12 |

**Pala bar. Mango madera /**  
*Spatula. Wood handle /*  
Palette. Manche en bois /  
*Schaufel. Holzgriff*

**P37506**



| REF      | Pala / Peel /<br>Pelle / Blatt<br>cm | L cm | €/u  |    |
|----------|--------------------------------------|------|------|----|
| P375.061 | 15,2 x 7,6                           | 29   | 4,20 | 12 |

**Espátula para untar. Mango madera /**  
*Butter spreader. Wood handle /*  
Couteau à beurre. Manche en bois /  
*Aufstrichspachtel. Holzgriff*

**P37511**



| REF      | Pala / Peel /<br>Pelle / Blatt<br>cm | L cm | €/u  |    |
|----------|--------------------------------------|------|------|----|
| P375.110 | 10,2 x 3,3                           | 19,7 | 1,70 | 12 |

**GUÍA SELECCIÓN RALLADORES / GRATERS SELECTION GUIDE / GUIDE SÉLECTION RAPÊS / AUSWAHLÜBERSICHT REIBEN**

|   | DOBLE NAVAJA /<br>RIBON /<br>TRANCHANTS /<br>DOPPELKLINGEN | TIRAS LARGAS /<br>LARGE SHAVER /<br>LARGE COUPE /<br>LANGE STREIFEN | FINO /<br>FINE /<br>FIN /<br>FEIN | MEDIO /<br>MEDIUM /<br>MOYEN /<br>MITTEL | GRUESO /<br>EXTRA COARSE /<br>GROS GRAINS /<br>GROB | DUAL /<br>DUAL /<br>DOUBLE /<br>DOPPEL |
|---|--|---|-----------------------------------|--|---|--|
| <b>Zanahoria / Carrot /</b><br><i>Carotte / Karotten</i>          | ✓  | ✓   |                                   |  |   | ✓                                      |
| <b>Cebolla / Onion /</b><br><i>Oignon / Zwiebel</i>               | ✓  |   |                                   | ✓  |   | ✓                                      |
| <b>Ajo / Garlic /</b><br><i>Ail / Knoblauch</i>                   |  |   | ✓                                 |  |   |  |
| <b>Chocolate</b><br><i>Schokolade</i>                             | ✓  |   | ✓                                 | ✓  | ✓   | ✓                                      |
| <b>Citricos / Citrus /</b><br><i>Citron / Zitronen</i>            |  | ✓   | ✓                                 | ✓  |   |  |
| <b>Patata / Potato /</b><br><i>Pomme de Terre / Kartoffel</i>     | ✓  | ✓   |                                   |  |   |  |
| <b>Manzana / Apple /</b><br><i>Pomme / Apfel</i>                  | ✓  | ✓   |                                   |  | ✓   |  |
| <b>Queso duro / Hard Cheese /</b><br><i>Fromage / Hartkäse</i>    | ✓  |   | ✓                                 | ✓  | ✓   | ✓                                      |
| <b>Queso blando / Soft Cheese /</b><br><i>Fromage / Weichkäse</i> | ✓  |   |                                   |  | ✓   |  |
| <b>Nuez / Nut /</b><br><i>Noix / Nüsse</i>                        |  |   | ✓                                 | ✓  |   | ✓                                      |
| <b>Pimiento / Pepper /</b><br><i>Poivron / Pfeffer</i>            |  |   | ✓                                 | ✓  |   | ✓                                      |
| <b>Tomate / Tomato /</b><br><i>Tomato / Tomaten</i>               |  |   |                                   | ✓  | ✓   |  |

**P328 Rallador / Grater / Râpe / Reibe**

**INOX - ST/STEEL**  
*ROSTFREIER STAHL*



Ref. P328.600

| REF      | Caras / Sides /<br>Facies / Seiten | cm        | H cm | €/u   |    |
|----------|------------------------------------|-----------|------|-------|----|
| P328.020 | 4                                  | 9 x 6,5   | 20,8 | 6,45  | 12 |
| P328.023 | 4                                  | 10,5 x 8  | 23,3 | 7,90  | 12 |
| P328.600 | 6                                  | 14,5 x 11 | 22,0 | 16,15 | 12 |

**P391 Rallador nuez moscada de acero inox / St/Steel nutmeg grater /**  
*Râpe à muscade en acier inox / Rostfreie Muskatnussreibe*



| REF      | €/u  |    |
|----------|------|----|
| P391.000 | 6,40 | 12 |

**P3221** Rallador acero inoxidable "slim" con mango / St/Steel "slim" grater with handle /  
Râpe inoxydable "slim" avec queue / Rostfreie Reibe "schmal" mit Griff

Ralladores de acero inoxidable. Mangos ergonómicos. Borde antideslizante  
St/Steel graters. Ergonomic and soft touch handles. Non-slip rubber end  
Râpes en acier inoxydable. Poignée ergonomique. Extrémité anti-dérapant  
Rostfreie Reiben. Ergonomische Griffe. Antirutschrand.

| REF      | cm         | €/u   | 📦 |
|----------|------------|-------|---|
| P322.101 | 39,5 x 3,5 | 11,90 | 1 |
| P322.102 | 39,5 x 3,5 | 11,90 | 1 |
| P322.103 | 39,5 x 3,5 | 11,90 | 1 |
| P322.104 | 39,5 x 3,5 | 11,90 | 1 |

**IDEA!** Especial cítricos /  
Ideal for citrus /  
Idéal pour agrumes /  
Ideal für Zitrusfrüchte

**BEST  
SELLER**



REF. P322.104  
Fino / Fine /  
Fin / Fein



REF. P322.101  
Dual / Dual /  
Double / Doppel



REF. P322.103  
Medio / Medium /  
Moyen / Medium



REF. P322.102  
Doble navaja / Ribon /  
Tranchants / Zwei Klängen

**P3222** Rallador acero inoxidable "wide" con mango / St/Steel "wide" grater with handle /  
Râpe inoxydable "wide" avec queue / Rostfreie Reibe "breit" mit Griff

Ralladores de acero inoxidable. Mangos ergonómicos. Borde antideslizante  
St/Steel graters. Ergonomic and soft touch handles. Non-slip rubber end  
Râpes en acier inoxydable. Poignée ergonomique. Extrémité anti-dérapant  
Rostfreie Reiben. Ergonomische Griffe. Antirutschrand.

| REF      | cm         | €/u   | 📦 |
|----------|------------|-------|---|
| P322.201 | 31,5 x 7,3 | 12,15 | 1 |
| P322.202 | 31,5 x 7,3 | 12,15 | 1 |
| P322.203 | 31,5 x 7,3 | 12,15 | 1 |
| P322.204 | 31,5 x 7,3 | 12,15 | 1 |

**IDEA!** Especial cítricos /  
Ideal for citrus /  
Idéal pour agrumes /  
Ideal für Zitrusfrüchte



REF. P322.204  
Fino / Fine /  
Fin / Fein



REF. P322.201  
Tiras largas / Large shaver /  
Large coupe / Lange Streifen



REF. P322.202  
Doble navaja / Ribon /  
Tranchants / Zwei Klängen



REF. P322.203  
Grueso / Extra coarse /  
Gros grains / Grob

**P374** Colador doble malla en acero inoxidable /  
St/Steel double mesh strainer /  
Passoire double maille en acier inox /  
Doppelmäschiges Sieb rostfrei



| REF      | Ø cm | L cm | Luz de malla /<br>Mesh size /<br>Mailage /<br>Maschenweite<br>mm | €/u   | 📦  |
|----------|------|------|--|-------|----|
| P374.013 | 13   | 30   | 1-3  | 5,50  | 72 |
| P374.015 | 15   | 32   | 1-3  | 6,60  | 72 |
| P374.018 | 18   | 34   | 1-3  | 7,40  | 72 |
| P374.020 | 20   | 38   | 1-3  | 8,30  | 72 |
| P374.026 | 26   | 58,5 | 1,6-3  | 22,55 | 72 |

**P324** Colador 1/2 bola reforzado en acero inox /  
St/Steel reinforced 1/2 ball colander /  
Passoire ronde renforcé en acier inox /  
Halbkugeliges Sieb rostfrei und verstärkt

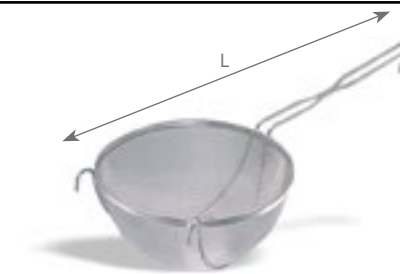

| REF      | Ø cm | L cm | Luz de malla /<br>Mesh size /<br>Mailage /<br>Maschenweite<br>mm | €/u   | 📦  |
|----------|------|------|--|-------|----|
| P324.013 | 13   | 36   | 0,530  | 18,60 | 12 |
| P324.016 | 16   | 40   | 0,530  | 22,25 | 12 |
| P324.019 | 19   | 42,5 | 0,530  | 28,60 | 12 |
| P324.022 | 22   | 49   | 0,530  | 33,35 | 12 |
| P324.025 | 25   | 55,5 | 0,530  | 41,25 | 12 |

**P325** Colador media bola en acero inox /  
St/Steel hemispherical strainer /  
Passoire demi-sphérique en acier inox /  
Halbrundes Sieb rostfrei



| REF      | Ø cm | L cm | Luz de malla /<br>Mesh size /<br>Mailage /<br>Maschenweite<br>mm | €/u   | 📦  |
|----------|------|------|--|-------|----|
| P325.008 | 8    | 22,5 | 0,700  | 4,75  | 96 |
| P325.010 | 10   | 25,2 | 0,700  | 6,90  | 96 |
| P325.012 | 12   | 32,5 | 0,700  | 8,80  | 96 |
| P325.015 | 15   | 40,2 | 0,700  | 11,45 | 72 |
| P325.018 | 18   | 42,5 | 0,700  | 14,40 | 72 |
| P325.020 | 20   | 44,5 | 0,700  | 20,05 | 72 |

**P375** Colador doble malla en acero inoxidable. Reforzado /  
St/Steel double mesh strainer. Reinforced /  
Passoire double maille en acier inox. Renforcé /  
Doppelmäschiges Sieb rostfrei und verstärkt

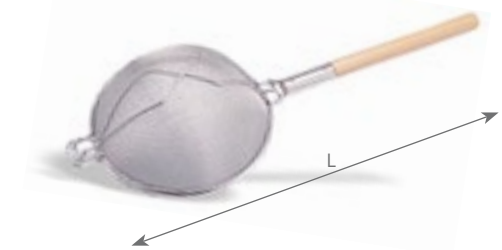

| REF      | Ø cm | L cm | Luz de malla /<br>Mesh size /<br>Mailage /<br>Maschenweite<br>mm | €/u   | 📦 |
|----------|------|------|--|-------|---|
| P375.030 | 30   | 79,0 | 1,040  | 71,20 | 1 |
| P375.035 | 35   | 86,5 | 1,040  | 76,55 | 1 |

**P348** Colador cónico en acero inoxidable /  
St/Steel conical strainer /  
Passoire conique en acier inox /  
Konisches Sieb rostfrei und verstärkt

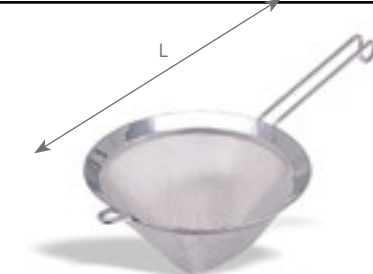

| REF      | Ø cm | L cm | Luz de malla /<br>Mesh size /<br>Mailage /<br>Maschenweite<br>mm | €/u   | 📦  |
|----------|------|------|--|-------|----|
| P348.008 | 8    | 22,5 | 0,700  | 5,35  | 96 |
| P348.010 | 10   | 24,5 | 0,700  | 7,00  | 96 |
| P348.012 | 12   | 31,5 | 0,700  | 9,15  | 96 |
| P348.015 | 15   | 35   | 0,700  | 11,15 | 96 |
| P348.018 | 18   | 40,5 | 0,700  | 15,10 | 72 |

**P373** Colador bayeta / Cotton strainer /  
Passe-bouillon / Textilsieb

Acero inoxidable y algodón  
St/Steel and cotton  
Acier inoxydable et coton  
Rostfrei und Baumwolle



| REF      | L cm | €/u   | 📦 |
|----------|------|-------|---|
| P373.020 | 20   | 24,40 | 6 |
| P373.024 | 24   | 30,55 | 6 |
| P373.028 | 28   | 48,90 | 6 |

**P303** Colador chino / Conical colander /  
Chinois / Spitzsieb



| REF      | Ø cm | H cm | €/u   |    |
|----------|------|------|-------|----|
| P303.016 | 16,8 | 34,8 | 16,25 | 12 |
| P303.018 | 18,6 | 38,4 | 16,80 | 12 |
| P303.020 | 21,1 | 39,7 | 17,40 | 12 |
| P303.022 | 23,2 | 44,0 | 20,15 | 12 |
| P303.024 | 25,1 | 46,0 | 21,50 | 12 |
| P303.026 | 27,2 | 47,8 | 22,50 | 12 |

**P970** Soporte para chino o embudo /  
Stand for chinese colander or funnel /  
Support pour chinois ou entonnoir /  
Ständer für Spitzsieb und Trichter



| REF      | Ø cm | H cm | €/u   |   |
|----------|------|------|-------|---|
| P970.000 | 16   | 19   | 23,30 | 1 |

**P347** Colador chino con malla /  
Conical colander with wire gauze /  
Chinois à gaze /  
Spitzsieb mit Maschen



| REF      | Ø cm | Luz de malla /<br>Mesh size /<br>Mailage /<br>Maschenweite<br>mm | €/u   |    |
|----------|------|--|-------|----|
| P347.020 | 20   | 0,700  | 27,50 | 12 |
| P347.024 | 24   | 0,700  | 34,95 | 12 |

**P3032** Triángulo / Triangle /  
Triangle / Dreieck



Triángulo equilátero  
Equilateral triangle  
Triangle équilatéral  
Gleichseitiges Dreieck

| REF      | L cm | €/u   |   |
|----------|------|-------|---|
| P303.200 | 29   | 12,90 | 1 |

Ver productos en / See products on / Voir produits en page / Siehe produkte in

P. 159

**EMBUDO DOSIFICADOR /  
CONFECTIONERY FUNNEL /  
ENTONNOIR DOSEUR /  
DOSIERUNGSTRICHTER**



**P308** Escurridera / Conical colander / Passoire conique / Konischer Seiher

INOX - ST/STEEL  
EDELSTAHL  
18/10



**BEST  
SELLER**

| REF      | Ø cm | H cm | €/u    |   |
|----------|------|------|--------|---|
| P308.030 | 30   | 16,0 | 83,05  | 1 |
| P308.035 | 35   | 16,5 | 96,85  | 1 |
| P308.040 | 40   | 18,0 | 109,35 | 1 |
| P308.045 | 45   | 19,5 | 126,95 | 1 |
| P308.050 | 50   | 22,5 | 149,65 | 1 |

EXTRA RESISTENTE /  
HEAVY DUTY /  
EXTRA RÉSISTANT /  
EXTRA-RESISTENT

**P109** Escurridera con aro / Conical colander / Passoire conique / Konischer Seiher mit Ring

ALUMINIO /  
ALUMINIUM



| REF      | Ø cm | H cm | €/u    |   |
|----------|------|------|--------|---|
| P109.035 | 35   | 16,5 | 80,20  | 1 |
| P109.040 | 40   | 17,5 | 92,35  | 1 |
| P109.045 | 45   | 20,0 | 107,45 | 1 |
| P109.050 | 50   | 22,5 | 119,75 | 1 |

**P300** Escurridera inox con base / St/steel colander with stand /  
Passoire inox sur pied / Seiher rostfrei mit Ständer

INOX - ST/STEEL  
ROSTFREIER STAHL



| REF      | Ø cm | H cm  | €/u   |   |
|----------|------|-------|-------|---|
| P300.024 | 24   | 11,50 | 17,05 | 1 |
| P300.030 | 30   | 13,50 | 25,50 | 1 |

**P3003** Escurridera de malla / Mesh conical colander / Passoire à maille / Maschensieb

INOX - ST/STEEL  
ROSTFREIER STAHL



**NEW!**

| REF      | Ø cm | H cm | €/u   |   |
|----------|------|------|-------|---|
| P300.325 | 25   | 12   | 12,75 | 1 |
| P300.335 | 35   | 18   | 29,55 | 1 |
| P300.340 | 40   | 18   | 35,20 | 1 |

**P321** Colador / Colander / Passoire / Seiher

INOX - ST/STEEL  
EDELSTAHL  
18/10



| REF      | Ø cm | €/u   |   |
|----------|------|-------|---|
| P321.020 | 20   | 45,30 | 1 |
| P321.022 | 22   | 51,15 | 1 |
| P321.024 | 24   | 59,15 | 1 |
| P321.026 | 26   | 66,75 | 1 |

**P313** Pasapurés / Vegetable sieve /  
Moulin à légumes / Passiermaschine



Con 2 discos inox. intercambiables /  
With 2 St/Steel interchangeable cutters /  
Avec 2 coupeurs inox interchangeables /  
Mit 2 auswechselbaren Scheiben rostfrei

| REF      | Ø cm | Ø cm<br>Filtro / Filter /<br>Filtre / Filter | €/u   | 📦 |
|----------|------|--|-------|---|
| P313.025 | 25   | 11,5   | 42,35 | 1 |
| P313.030 | 30   | 14,5   | 64,90 | 1 |

**P945** Harinero / Flour bin /  
Tamis à farine / Mehlsieb

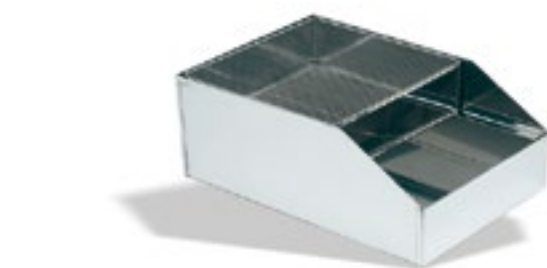

| REF      | cm             | €/u    | 📦 |
|----------|----------------|--------|---|
| P945.037 | 37 x 26,5 x 18 | 119,10 | 1 |
| P945.050 | 50 x 26,5 x 18 | 123,95 | 1 |
| P945.051 | 50 x 33 x 18   | 134,50 | 1 |

**P958** Gancho acero inoxidable 1p. /  
St/Steel hook 1p. / Crochet inox 1p. /  
Haken rostfrei 1 St.



Precio caja 10 unidades  
Price 10 units box  
Prix colis 10 unités  
Preis Kiste 10 Teile

| REF      | L cm | Ø mm | €/pack | 📦  |
|----------|------|------|--------|----|
| P958.010 | 10   | 4    | 6,60   | 10 |
| P958.012 | 12   | 5    | 9,10   | 10 |
| P958.014 | 14   | 6    | 10,75  | 10 |
| P958.016 | 16   | 6    | 11,85  | 10 |
| P958.018 | 18   | 6    | 13,35  | 10 |

**P3131** Pasapurés / Vegetable sieve /  
Moulin à légumes / Passiermaschine



Con 2 discos inox. intercambiables /  
With 2 St/Steel interchangeable cutters /  
Avec 2 coupeurs inox interchangeables /  
Mit 2 auswechselbaren Scheiben rostfrei

| REF      | Ø cm | Ø cm<br>Filtro / Filter /<br>Filtre / Filter | €/u    | 📦 |
|----------|------|--|--------|---|
| P313.126 | 26   | 16,5   | 94,15  | 1 |
| P313.132 | 32   | 16,5   | 101,65 | 1 |

**P3135** Pasapurés / Potato ricer /  
Presse-purés / Kartoffelpresse



| REF      | Ø cm | L cm | €/u   | 📦 |
|----------|------|------|-------|---|
| P313.500 | 9    | 30,5 | 30,40 | 1 |

**P954** Embudo con filtro extraíble /  
Funnel with removable filter /  
Entonnoir avec filtre extractible /  
Trichter mit herausnehmbarem Filter



| REF      | Ø A cm | H B cm | €/u   | 📦 |
|----------|--------|--------|-------|---|
| P954.013 | 13     | 2,6    | 18,70 | 1 |
| P954.015 | 15     | 2,6    | 20,30 | 1 |
| P954.020 | 20     | 3,2    | 21,80 | 1 |
| P954.025 | 25     | 3,2    | 24,80 | 1 |

**P868** Dispensador a presión / Squeeze dispenser / Distributeur à pression / Einzeldosierer



**BEST  
SELLER**

| REF       | COLOR | ml  | H cm | Ø cm | €/u  | 📦  |
|-----------|-------|-----|------|------|------|----|
| P868.001  | ● ●   | 240 | 18,0 | 5    | 1,10 | 12 |
| P868.002  | ● ●   | 360 | 21,0 | 5    | 1,30 | 12 |
| P868.003  | ● ●   | 720 | 24,5 | 5    | 1,90 | 12 |
| P868.004  | ● ●   | 240 | 18,0 | 5    | 1,10 | 12 |
| P868.005  | ● ●   | 360 | 21,0 | 5    | 1,30 | 12 |
| P868.006  | ● ●   | 720 | 24,5 | 5    | 1,90 | 12 |
| P868.007* | ○ ○   | 240 | 18,0 | 5    | 1,10 | 12 |
| P868.008* | ○ ○   | 360 | 21,0 | 5    | 1,30 | 12 |
| P868.009* | ○ ○   | 720 | 24,5 | 5    | 1,90 | 12 |

\* Transparente / Clear / Transparent

**2808-13** Dispensador a presión / Squeeze dispenser / Distributeur à pression / Einzeldosierer



| REF     | COLOR | ml  | H cm | Ø cm | €/u  | 📦  |
|---------|-------|-----|------|------|------|----|
| 2808-13 | ○ ○   | 240 | 18,4 | 5,0  | 1,90 | 12 |
| 2812-13 | ○ ○   | 350 | 18,4 | 6,0  | 2,30 | 12 |
| 4916-13 | ○ ○   | 470 | 18,7 | 7,5  | 2,95 | 12 |
| 4924-13 | ○ ○   | 710 | 26,0 | 7,3  | 3,35 | 12 |
| 4932-13 | ○ ○   | 950 | 26,4 | 8,3  | 4,20 | 12 |

Transparente / Clear / Transparent

**2208-1354** Dispensador a presión doble / Twin squeeze dispenser /  
Distributeur à pression double / Zweifachdosierer



| REF       | COLOR | ml  | H cm | Ø cm | €/u  | 📦  |
|-----------|-------|-----|------|------|------|----|
| 2208-1354 | ○ ●   | 200 | 18,0 | 5    | 2,75 | 12 |

Transparente / Clear / Transparent

**IDEA!** Ideal para decoración  
Ideal for dish presentation  
Idéal pour decoration  
Ideal für die Dekoration



**3316-13191** Dispensador a presión triple / Tri squeeze dispenser /  
Distributeur à pression triple / Dreifachdosierer



| REF        | COLOR | ml  | H cm | Ø cm | €/u  | 📦  |
|------------|-------|-----|------|------|------|----|
| 3316-13    | ○ ○   | 470 | 18,7 | 7,5  | 5,95 | 12 |
| 3332-13    | ○ ○   | 950 | 25,4 | 8,6  | 7,25 | 12 |
| 3316-13191 | ○ ●   | 500 | 18,0 | 5    | 6,05 | 12 |

Transparente / Clear / Transparent

**IDEA!** Ideal para decoración  
Ideal for dish presentation  
Idéal pour decoration  
Ideal für die Dekoration



**2908** Dispensador a presión con tapón cierre rosca / Squeeze dispenser with open-close system cap /  
Distributeur pressurisation a/capuchon d'ouverture-fermeture / Druckdosierer mit Schraubdeckel



| REF     | ml  | H cm | Ø cm | €/u  | 📦 |
|---------|-----|------|------|------|---|
| 2908-13 | 240 | 18,4 | 5,1  | 1,90 | 1 |
| 2912-13 | 350 | 18,4 | 6,0  | 2,05 | 1 |
| 5324-13 | 710 | 24,4 | 7,3  | 2,75 | 1 |

Transparente / Clear / Transparent



**26120** Dispensador a presión con tapón / Squeeze dispenser with cap /  
Distributeur pression avec capuchon / Druckdosierer mit Deckel



| REF      | ml  | H cm | Ø cm | €/u  | 📦 |
|----------|-----|------|------|------|---|
| 26120-13 | 350 | 16,2 | 6,2  | 2,20 | 1 |
| 26240-13 | 710 | 22,5 | 7,5  | 3,10 | 1 |
| 26320-13 | 950 | 22,9 | 8,6  | 4,45 | 1 |

Transparente / Clear / Transparent



**4961** Especieros / Dredgers / Saupoudreuses / Streuer



| REF        | ml  | Ø cm<br>Agujeros /<br>Holes /<br>Trous / Löcher | Ø cm | H cm | €/u  | 📦 |
|------------|-----|---|------|------|------|---|
| 4961-13191 | 470 | 0,14  | 7,3  | 16   | 4,60 | 1 |
| 4961-1332  | 470 | 0,25  | 7,3  | 16   | 4,45 | 1 |
| 4961-1308  | 470 | 0,46  | 7,3  | 16   | 4,45 | 1 |
| 4961-1301  | 470 | 0,94  | 7,3  | 16   | 4,45 | 1 |

Transparente / Clear / Transparent

**P946** Especieros / Dredgers / Saupoudreuses / Streuer



| REF        | Ø cm | H cm | Ø mm | €/u  | 📦  |
|------------|------|------|------|------|----|
| A P946.001 | 7    | 9,6  | -    | 7,60 | 12 |
| B P946.002 | 7    | 9,6  | 2    | 6,25 | 12 |
| C P946.003 | 7    | 9,6  | 3    | 6,35 | 12 |
| D P946.004 | 7    | 9,6  | 4    | 6,25 | 12 |

Especiero "A" con malla  
Dredger "A" with mesh  
Saupoudreuse "A" maillée  
Streuer "A" mit Maschen

Con tapón de plástico  
With plastic cover  
Avec couvercle en plastique  
Mit Plastideckel



**P870** Molde huevo sandwich redondo /  
Round egg ring /  
Moule à oeuf rond /  
Runde Sandwicheierform



| REF      | Ø cm | H cm | €/u  | 📦 |
|----------|------|------|------|---|
| P870.000 | 8,5  | 11,0 | 2,80 | 1 |

**P871** Molde huevo sandwich cuadrado /  
Squared egg mould /  
Moule à oeuf carré /  
Rechteckige Spiegeleierform



| REF      | cm        | H cm | €/u  | 📦 |
|----------|-----------|------|------|---|
| P871.000 | 8,5 x 8,5 | 11,0 | 2,80 | 1 |

**P905** Aplastacarnes inox forjado /  
Solid St/Steel meat beater /  
Aplatisseur inox forgé /  
Solider Fleischstampfer rostfrei



| REF      | Ø cm | Kg  | L cm | €/u   | 📦 |
|----------|------|-----|------|-------|---|
| P905.015 | 10   | 1,5 | 14   | 46,35 | 1 |

**P942 / P943** Aplastadora carne /  
Meat tenderizer /  
Aplatisseur à viande/  
Fleischstampfer



| REF      | Ø cm | Kg    | L cm | €/u   | 📦 |
|----------|------|-------|------|-------|---|
| P942.000 | 9,5  | 0,750 | 28,5 | 26,50 | 1 |
| P943.000 | 9,5  | 0,750 | 28,5 | 26,50 | 1 |

**5.1** UTENSILIOS DE COCINA / KITCHEN UTENSILS /  
USTENSILES DE CUISINE / KÜCHENUTENSILIEN

**P334**

Alcuza / Oil pourer / Huilière / Ölkanne



| REF      | Lts  | €/u   |   |
|----------|------|-------|---|
| P334.050 | 0,50 | 25,50 | 1 |
| P334.100 | 1,00 | 33,45 | 1 |

**Barra de notas de aluminio /**  
Aluminium check minder /  
Barre porte-bons en aluminium /  
Aluminiumleiste für Notizen

**P873**



| REF      | L cm | H cm | €/u   |   |
|----------|------|------|-------|---|
| P873.045 | 45   | 5,0  | 11,20 | 1 |
| P873.060 | 60   | 5,0  | 13,75 | 1 |
| P873.090 | 90   | 5,0  | 20,75 | 1 |

**P8180** Cepillo metálico / Metallic brush /  
Brosse métallique / Metallbürste



**Ideal para hornos, brasa y barbecue**  
Ideal for ovens, grills and barbecues  
Idéal pour fours, grill et barbecue  
Ideal für Öfen, Kohlenfeuer und Grillanlagen

| REF      | L cm | €/u  |   |
|----------|------|------|---|
| P818.000 | 27   | 2,20 | 1 |

UTENSILIOS DE COCINA / KITCHEN UTENSILS /  
USTENSILES DE CUISINE / KÜCHENUTENSILIEN

**P94009**

Remo acero inoxidable / St/Steel mixing paddle /  
Spatule géante inoxydable / Rührpaddel rostfrei



| REF      | Pala / Peel /<br>Pelle / Blatt<br>cm | L cm | €/u   |   |
|----------|--------------------------------------|------|-------|---|
| P940.090 | 12 x 19                              | 90   | 38,45 | 1 |
| P940.120 | 16 x 19,5                            | 120  | 47,05 | 1 |

**Rascador con mango aluminio /**  
Grill scraper aluminium /  
Raclette à plancha /  
Schaber mit Aluminiumgriff

**P940**



| REF       | cm               | €/u   |   |
|-----------|------------------|-------|---|
| P940.000  | 44,5 x 12 x 12,7 | 39,00 | 1 |
| RE940.001 | 12,7 x 7,7       | 7,90  | 1 |

**P944** Escamador / Fish scaler /  
Ecailleur / Fischentschupper



| REF      | L cm | €/u  |   |
|----------|------|------|---|
| P944.000 | 23,5 | 3,20 | 1 |

**REDCO® PUJADAS®**

**AMPLIA GAMA DE PROCESADORES DE ALIMENTOS MANUALES**

Corta verduras y frutas  
Hasta 11 veces más rápido que el corte a mano  
Fácil intercambio de las cuchillas  
Limpieza rápida y fácil

**WIDE RANGE OF MANUAL FOOD PROCESSORS**

Cuts both fruit and vegetables  
Speed up your work 11 times faster than hand cutting  
Easy-to-remove interchangeable blades  
Easy to clean

**LARGE GAMME D'APPAREILS MANUELS DE TRANSFORMATION DES ALIMENTS**

Coupe les légumes et les fruits  
Jusqu'à 11 fois plus rapide que lorsque vous coupez à la main  
Couteaux facilement interchangeables  
Nettoyage rapide et facile

**GROSSE AUSWAHL AN HANDLICHEN SCHNEIDEMASCHINEN**

Geeignet für Obst und Gemüse  
11Mal schneller als Handschneiden  
Müheleose Austauschbarkeit der Klingen  
Schnelle und einfache Reinigung



DADOS Y BASTONCILLOS /  
DICE & STICKS /  
CUBES ET BÂTONNETS /  
WÜRFEL UND STÄBCHEN



REBANADA /  
SLICE /  
TRANCHES /  
SCHEIB



GAJOS /  
WEDGE /  
QUARTIERS /  
ZERTEILER



SACACORAZONES /  
CORE /  
ÉVIDOIR /  
ENTKERNER



UTENSILIOS /  
UTENSILS /  
USTENSILES

**PROCESADORES MANUALES DE ALIMENTOS /**  
*MANUAL FOOD PROCESSORS /*  
**APPAREILS MANUELS DE TRANSFORMATION DES ALIMENTS /**  
*MANUELLE KÜCHENMASCHINEN*



\* VELOCIDADES / SPEEDS /  
VITESSES / GESCHWINDIGKEITEN

|  |      |      |   |
|--|------|------|---|
| <b>Limones / Lemons</b><br>Citrons / Zitronen                |      |      |   |
| <b>Limas / Limes</b><br>Citrons verts / Limonen              |      |      |   |
| <b>Naranjas / Oranges</b><br>Oranges / Orangen               |      |      |   |
| <b>Tomates / Tomatoes</b><br>Tomates / Tomaten               | ✓    | ✓    |   |
| <b>Cebollas / Onions</b><br>Oignons / Zwiebeln               | ✓    | ✓    | ✓ |
| <b>Apio / Celery</b><br>Céleri / Stangensellerie             | ✓    | ✓    |   |
| <b>Pimientos / Peppers</b><br>Poivrons / Paprikaschoten      | ✓    | ✓    |   |
| <b>Patatas / Potatoes</b><br>Pommes de terre / Kartoffeln    | ✓    | ✓    |   |
| <b>Manzanas / Apples</b><br>Pommes / Äpfel                   | ✓ 4x | ✓ 4x |   |
| <b>Peras / Pears</b><br>Poires / Birnen                      | ✓ 4x | ✓ 4x |   |
| <b>Lechuga / Lettuce</b><br>Laitue / Kopfsalat               |      |      | ✓ |
| <b>Pimientos / Bell peppers</b><br>Poivrons / Paprikaschoten | ✓    |      | ✓ |
| <b>Pepino / Cucumbers</b><br>Concombres / Gurken             |      |      | ✓ |

\* **Veces más rápido que cortar a mano.**  
*Faster than cutting by hand.*  
*Fois plus rapide qu'une coupe à la main.*  
*Schneller als das Schneiden von Hand.*

**Reduzca el tiempo de mano de obra /**  
*Reduce labor time /*  
**Réduisez le temps de travail /**  
*Reduzieren Sie Ihre Arbeitszeit*



|  |            |             |           |           |           |
|--|------------|-------------|-----------|-----------|-----------|
|  | <b>11x</b> | <b>2,5x</b> | <b>3x</b> | <b>3x</b> | <b>5x</b> |
|  |            | ✓           | ✓         | ✓         |           |
|  |            | ✓           | ✓         | ✓         |           |
|  |            | ✓           | ✓         | ✓         |           |
|  |            |             | ✓         | ✓         | ✓         |
|  |            | ✓           |           |           |           |
|  |            |             |           |           |           |
|  |            |             |           |           |           |
|  |            |             |           |           |           |
|  |            |             |           |           |           |
|  | ✓          |             |           |           |           |
|  |            |             |           |           |           |
|  |            |             |           |           |           |





**55457** Cortador-Rebanador de sobremesa grande / Big size tabletop dicer & slicer /  
Grand Coupe légumes en tranches et cubes / Grösser Tisch Würfelschneider und -hobel für Arbeitsflächen

**NSF** **InstaCut™ 5.0** **Sobremesa / Tabletop / À poser / Arbeitsflächen**



| REF  | TIPO / TYPE | CORTE / CUT<br>COUPE / SCHNITT<br>mm | €/u    |   |
|--|-------------|--------------------------------------|--------|---|
| <b>DADOS - BASTONCILLOS / DICE &amp; STICKS / CUBES ET BÂTONNETS / WÜRFEL UND STÄBCHEN</b> |             |                                      |        |   |
| 55457  |             | 6,4 ●                                | 334,20 | 1 |
| 55458  |             | 9,5                                  | 333,55 | 1 |
| 55459  |             | 12,7                                 | 333,35 | 1 |
| <b>REBANADA / SLICE / TRANCHES / SCHEIB</b>  |             |                                      |        |   |
| 55460  |             | 6,4 ●                                | 358,00 | 1 |

Los artículos marcados con cada punto de color son compatibles entre ellos /  
Items marked with the same coloured dot are compatible with each other /  
Les articles marqués d'un point de couleur sont compatibles /  
Die mit den einzelnen Farbpunkten gekennzeichneten Artikel sind miteinander kombinierbar.

● ●

Adaptable a / Adjustable to /  
Adaptable à / geeignet für

**Dentro / Inside /  
Dans / Innerhalb (max)**  
1/3 100 mm  
1/4 150 mm  
1/6 150 mm

**Fuera / Outside /  
Extérieur / Außerhalb (max)**  
1/1 200 mm

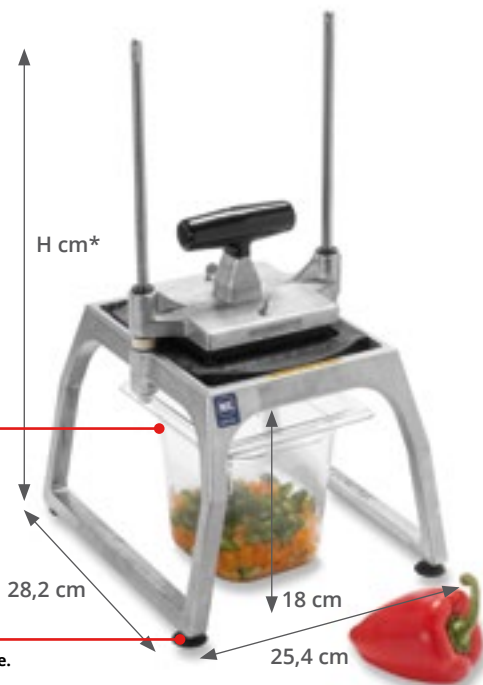

Con ventosas de agarre en la base.  
With suction base.  
Avec ventouse d'accrochement à la base.  
Mit Saugfüssen.

\*H 50,8 cm **Abierto / Open / Ouvert / Offen**  
\*H 47 cm **Cerrado / Closed / Fermé / Geschlossen**

**3X Más rápido / Faster**

**4X Más rápido / Faster**

**Asa en T, bloque de empuje y cuchilla /  
T-handle, pusher block and blade /  
Poignée en T, bloc de poussée et lame /  
T-griff, druckblock und messer**

| TIPO/TYPE  | REF     | mm   | €/u    |
|--|---------|------|--------|
| <b>DADOS - BASTONCILLOS / DICE &amp; STICKS / CUBES ET BÂTONNETS / WÜRFEL UND STÄBCHEN</b> |         |      |        |
|  | ● 55483 | 6,4  | 237,45 |
|  | 55484   | 9,5  | 239,25 |
|  | 55485   | 12,7 | 230,80 |

|   |         |     |        |
|---|---------|-----|--------|
| <b>REBANADA / SLICE / TRANCHES / SCHEIB</b> |         |     |        |
|   | ● 55486 | 6,4 | 270,60 |

| <b>SECCIONES / SECTION / QUARTIERS / STÜCK</b> |         |    |        |
|--|---------|----|--------|
| <b>GAJOS / WEDGE / QUARTIERS / ZERTEILER</b>   |         |    |        |
|  | ● 55490 | 6  | 221,95 |
|  | 55491   | 8  | 221,65 |
|  | 55492   | 10 | 221,95 |
|  | ● 55493 | 12 | 221,95 |

|   |         |   |        |
|---|---------|---|--------|
| <b>SACACORAZONES / CORE / ÉVIDOIR / ENTKERNER</b> |         |   |        |
|   | ● 55494 | 6 | 224,65 |
|   | 55495   | 8 | 220,25 |

**Sólo cuchilla de reemplazo /  
Replacement blade only /  
Lame de rechange seule /  
Nur ersatzmesser**

| REF     | €/u    |
|---------|--------|
| ● 55470 | 140,75 |
| 55471   | 138,75 |
| ● 55472 | 144,15 |

|         |        |
|---------|--------|
| ● 55473 | 163,75 |
|---------|--------|

|         |        |
|---------|--------|
| ● 55477 | 137,15 |
| 55478   | 137,35 |
| 55479   | 137,35 |
| ● 55480 | 137,35 |

|         |        |
|---------|--------|
| ● 55481 | 169,25 |
| 55482   | 169,45 |

**15000** Cortador-Rebanador de sobremesa pequeño / Small size tabletop dicer & slicer /  
 Coupe légumes en tranches et cubes de table / Kleiner Tisch Würfelschneider und - hobel für Arbeitsflächen

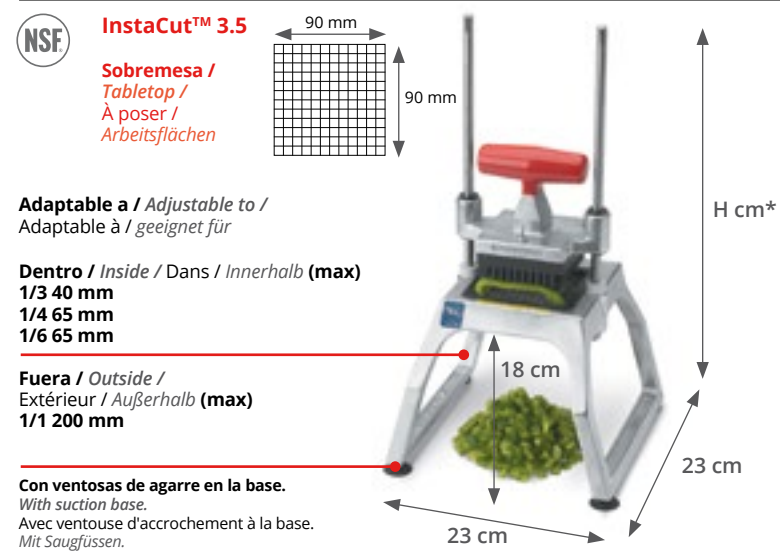

| REF  | TIPO / TYPE | CORTE / CUT<br>COUPE / SCHNITT<br>mm | €/u    | 📦 |
|--|-------------|--------------------------------------|--------|---|
| <b>DADOS - BASTONCILLOS / DICE &amp; STICKS / CUBES ET BÂTONNETS / WÜRFEL UND STÄBCHEN</b> |             |                                      |        |   |
| 15000  |             | 6,4                                  | 337,55 | 1 |
| 15001  |             | 9,5                                  | 337,55 | 1 |
| 15002  |             | 12,7                                 | 302,20 | 1 |

| REF  | TIPO / TYPE | SECCIONES / SECTION /<br>QUARTIERS / STÜCK | €/u    | 📦 |
|--|-------------|--|--------|---|
| <b>GAJOS / WEDGE / QUARTIERS / ZERTEILER</b> |             |  |        |   |
| 15005  |             | 6  | 303,35 | 1 |
| 15006  |             | 8  | 337,55 | 1 |
| 15007  |             | 10   | 304,50 | 1 |

\*H 45,7 cm Abierto / Open / Ouvert / Offen  
 \*H 43,5 cm Cerrado / Closed / Fermé / Geschlossen



**15016** Cortador-Rebanador de pared / Wall mount dicer & slicer /  
 Coupe légumes fixation murale / Tischwürfelschneider und - hobel zur Wandmontage

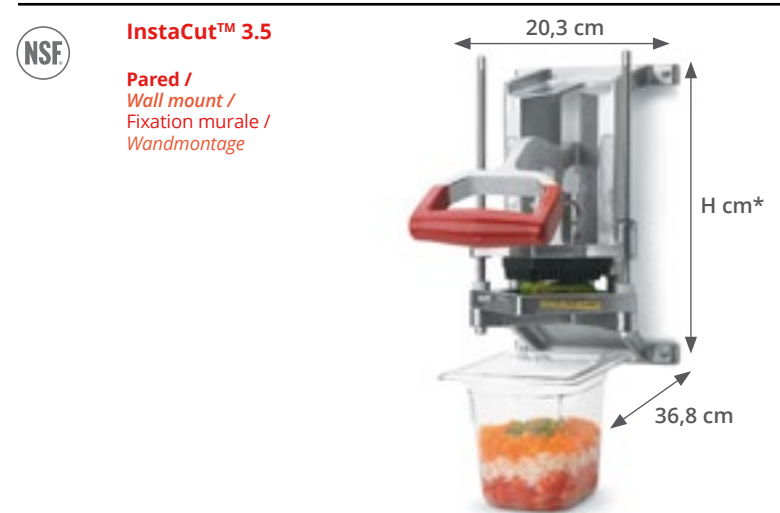

| REF  | TIPO / TYPE | CORTE / CUT<br>COUPE / SCHNITT<br>mm | €/u    | 📦 |
|--|-------------|--------------------------------------|--------|---|
| <b>DADOS - BASTONCILLOS / DICE &amp; STICKS / CUBES ET BÂTONNETS / WÜRFEL UND STÄBCHEN</b> |             |                                      |        |   |
| 15016  |             | 6,4                                  | 441,45 | 1 |
| 15017  |             | 9,5                                  | 441,35 | 1 |

Asa en T, bloque de empuje y cuchilla / T-handle, pusher block and blade /  
 Poignée en T, bloc de poussée et lame / T-griff, druckblock und messer

| Ref. 15000 - 15010   |       |            |        | Ref. 15016 - 15024 |        |
|--|-------|------------|--------|--------------------|--------|
| TIPO / TYPE  | REF   | mm         | €/u    | REF                | €/u    |
| <b>DADOS - BASTONCILLOS / DICE &amp; STICKS / CUBES ET BÂTONNETS / WÜRFEL UND STÄBCHEN</b> |       |            |        |                    |        |
|  | 15059 | 6,4        | 206,60 | 15081              | 178,25 |
|  | 15060 | 9,5        | 206,50 | 15082              | 178,15 |
|  | 15061 | 12,7       | 206,75 | 15083              | 178,40 |
|  | 15085 | 6,4 x 12,7 | 207,45 | -                  | -      |
| <b>SECCIONES / SECTION / QUARTIERS / STÜCK</b>   |       |            |        |                    |        |
| <b>GAJOS / WEDGE / QUARTIERS / ZERTEILER</b>   |       |            |        |                    |        |
|  | 15050 | 4          | 207,65 | 15073              | 179,20 |
|  | 15052 | 6          | 210,35 | -                  | -      |
|  | 15053 | 8          | 210,80 | 15076              | 179,50 |
|  | 15054 | 10         | 211,55 | -                  | -      |
|  | 15055 | 12         | 210,80 | 15078              | 179,90 |
| <b>SACACORAZONES / CORE / ÉVIDOIR / ENTKERNER</b>  |       |            |        |                    |        |
|  | 15058 | 8          | 226,95 | -                  | -      |

Sólo cuchilla de reemplazo /  
 Replacement blade only /  
 Lame de rechange seule /  
 Nur ersatzmesser

| REF   | €/u    |
|-------|--------|
| 15062 | 113,80 |
| 15063 | 113,50 |
| 15064 | 113,50 |
| 15086 | 112,10 |
| 15065 | 114,95 |
| 15067 | 116,60 |
| 15068 | 113,20 |
| 15069 | 110,85 |
| 15070 | 111,00 |
| 15072 | 114,65 |

**47713** Cortador de patatas / Potato cutter /  
 Coupe-pommes de terre / Pommes-Frites-Schneider

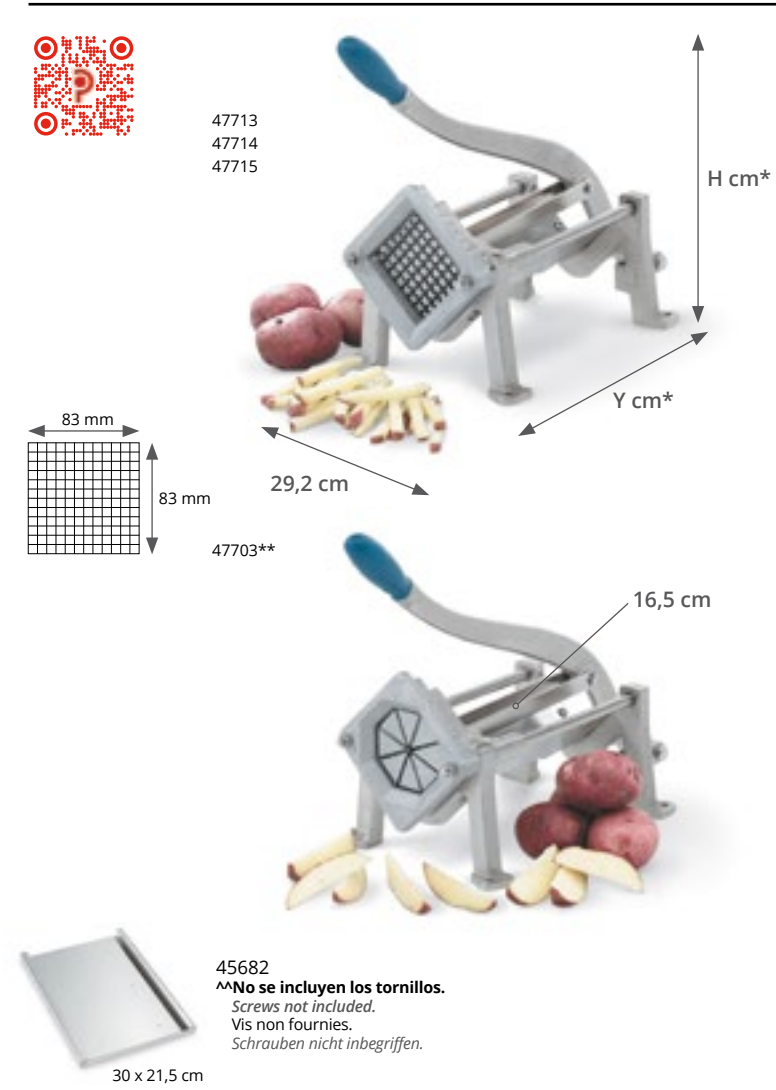

| REF  | TIPO / TYPE | CORTE / CUT<br>COUPE / SCHNITT<br>mm | €/u    | 📦 |
|--|-------------|--------------------------------------|--------|---|
| <b>DADOS - BASTONCILLOS / DICE &amp; STICKS / CUBES ET BÂTONNETS / WÜRFEL UND STÄBCHEN</b> |             |                                      |        |   |
| 47713  |             | 7                                    | 295,40 | 1 |
| 47714  |             | 10                                   | 295,40 | 1 |

\*Y 87,6 cm H 58,4 cm Abierto / Open / Ouvert / Offen  
 \*Y 45,0 cm H 35,6 cm Cerrado / Closed / Fermé / Geschlossen

Sólo cuchilla de reemplazo / Replacement blade only /  
 Lame de rechange seule / Nur ersatzmesser

| REF  | TIPO / TYPE | CORTE / CUT<br>COUPE / SCHNITT<br>mm | €/u   | 📦 |
|--|-------------|--------------------------------------|-------|---|
| <b>DADOS - BASTONCILLOS / DICE &amp; STICKS / CUBES ET BÂTONNETS / WÜRFEL UND STÄBCHEN</b> |             |                                      |       |   |
| 45751-1  |             | 7                                    | 42,60 | 1 |
| 45749-1  |             | 10                                   | 42,60 | 1 |

Agujeros para tornillos en la base de las patas para el montaje permanente en mesas o paredes.  
 Screw holes on base of legs for permanent mounting to table or wall.

Trous à vis sur la base des pieds pour fixation permanente sur une table ou un mur.  
 Schraubenlöcher im Boden der Standfüße zur dauerhaften Befestigung an Tisch oder Wand.

\*\*Se ofrecen cuchillas y piezas adicionales.  
 Extra blades and parts available.  
 Lames et pièces supplémentaires disponibles.  
 Zusätzliche Messer und Teile erhältlich.

**P975** Cortador de patatas fritas / French fry cutter / Coupe frites / Pommeschneider

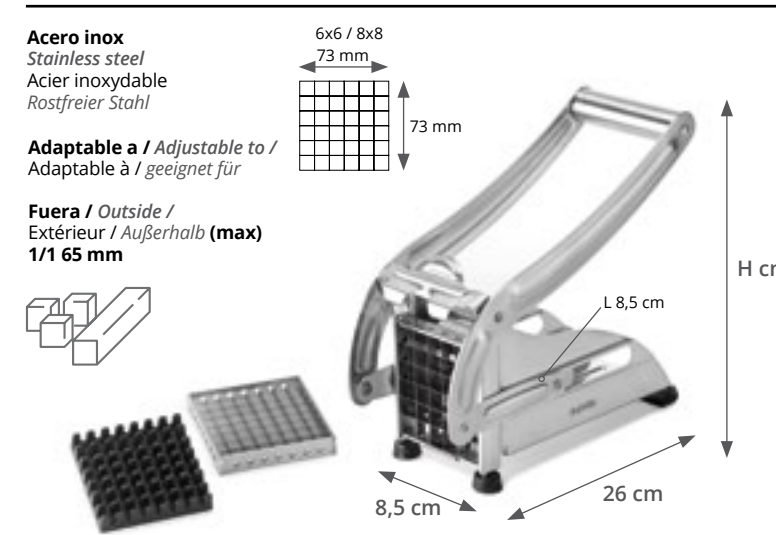

| REF      | CORTE / CUT<br>COUPE / SCHNITT<br>mm | AGUJEROS / HOLES /<br>TROUS / LÖCHER | €/u   | 📦 |
|----------|--------------------------------------|--------------------------------------|-------|---|
| P975.000 | 12 / 9                               | 36 / 64                              | 52,25 | 1 |

\*H 30 cm Abierto / Open / Ouvert / Offen  
 \*H 13 cm Cerrado / Closed / Fermé / Geschlossen

Sólo cuchilla de reemplazo / Replacement blade only /  
 Lame de rechange seule / Nur ersatzmesser

| REF        | CORTE / CUT<br>COUPE / SCHNITT<br>mm | AGUJEROS / HOLES /<br>TROUS / LÖCHER | €/u  | 📦 |
|------------|--------------------------------------|--------------------------------------|------|---|
| RE 975.001 | 12                                   | 36 (6 x 6)                           | 7,60 | 1 |
| RE 975.002 | 9                                    | 64 (8 x 8)                           | 7,70 | 1 |

**400N** Cortador de lechuga / Salad cutter / Coupe-Salade / Salatschneider



**LETTUCE KING® I**

| REF   | TIPO / TYPE | CORTE / CUT<br>COUPE / SCHNITT<br>mm | AGUJEROS / HOLES /<br>TROUS / LÖCHER | €/u    | 📦 |
|-------|-------------|--------------------------------------|--------------------------------------|--------|---|
| 400N  |             | 4,8                                  | 37                                   | 698,85 | 1 |
| 402NC |             | 9,5                                  | 19                                   | 681,55 | 1 |

\*Y 48,3 cm H 45,7 cm Abierto / Open / Ouvert / Offen  
 \*Y 59,1 cm H 43,5 cm Cerrado / Closed / Fermé / Geschlossen

**Conjunto de cuchillas / Blade assembly /**  
**Jeu de lames / Messereinheit**

| REF  | PARA / FOR /<br>POUR / FÜR | CORTE / CUT<br>COUPE / SCHNITT<br>mm | CUCHILLAS /<br>BLADES /<br>LAMES / MESSER | €/u    | 📦 |
|--|----------------------------|--------------------------------------|---|--------|---|
| <b>DADOS - BASTONCILLOS / DICE &amp; STICKS / CUBES ET BÂTONNETS / WÜRFEL UND STÄBCHEN</b> |                            |                                      |   |        |   |
| 435  | 400N                       | 4,8                                  | 37  | 116,05 | 1 |
| 485  | 403N                       | 6,4                                  | 28  | 107,95 | 1 |
| 484C   | 402NC                      | 9,5                                  | 19  | 106,90 | 1 |

**Corte un cuarto de cabeza de lechuga a la vez.**  
 Cut a quarter head of lettuce at a time.  
 Coupez un quart de tête de laitue à la fois.  
 Schneidet jeweils ein Salatkopfviertel.

**5X Más rápido / Faster**



**Adaptable a /**  
**Adjustable to /**  
**Adaptable à /**  
**Geeignet für (max)**  
**1/1 100 mm**  
**1/2 150 mm**



434  
17 x 15 cm

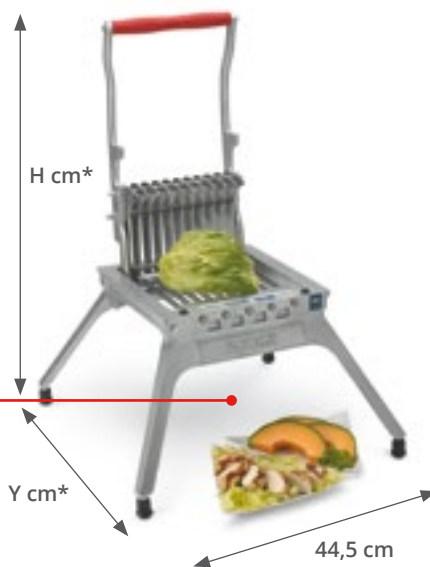

**4400N** Cortador de lechuga / Salad cutter / Coupe-Salade / Salatschneider



**LETTUCE KING® IV**

| REF  | TIPO / TYPE | CORTE / CUT<br>COUPE / SCHNITT<br>mm | €/u    | 📦 |
|--|-------------|--------------------------------------|--------|---|
| <b>DADOS - BASTONCILLOS / DICE &amp; STICKS / CUBES ET BÂTONNETS / WÜRFEL UND STÄBCHEN</b> |             |                                      |        |   |
| 4400N  |             | 25,4 x 25,4                          | 821,00 | 1 |

\*Y 43,2 cm H 81,3 cm Abierto / Open / Ouvert / Offen  
 \*Y 47 cm H 54,9 cm Cerrado / Closed / Fermé / Geschlossen

**Conjunto de cuchillas / Blade assembly /**  
**Jeu de lames / Messereinheit**

| REF  | TIPO / TYPE | CORTE / CUT<br>COUPE / SCHNITT<br>mm | €/u    | 📦 |
|--|-------------|--------------------------------------|--------|---|
| <b>DADOS - BASTONCILLOS / DICE &amp; STICKS / CUBES ET BÂTONNETS / WÜRFEL UND STÄBCHEN</b> |             |                                      |        |   |
| 4408   |             | 25,4 x 25,4                          | 117,40 | 1 |

**No oscurece la lechuga.**  
 Does not bruise the lettuce.  
 N'abîme pas la laitue.  
 Vermeidet Verletzungen der empfindlichen Salatblätter

**5X Más rápido / Faster**

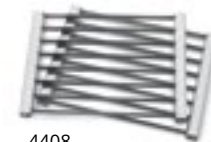

4408

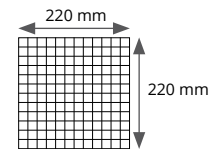

**Adaptable a /**  
**Adjustable to /**  
**Adaptable à /**  
**Geeignet für (max)**  
**1/1 200 mm**  
**1/2 200 mm**

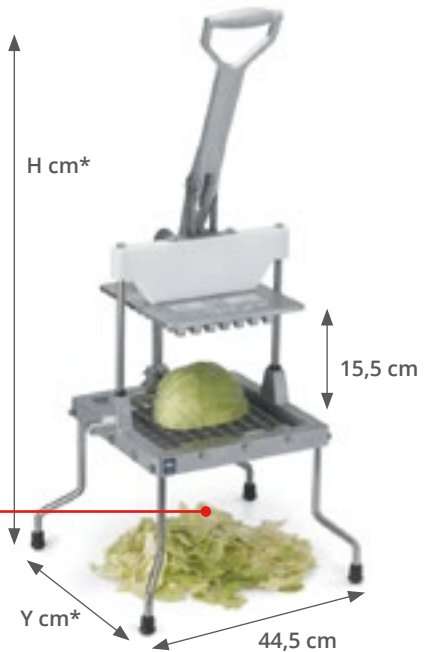

**403NH** Rebanadora de frutas y verduras / Fruit & vegetable slicer / Coup-fruit et légumes / Obstschneider



**Adaptable a /**  
**Adjustable to /**  
**Adaptable à /**  
**Geeignet für (max)**  
**1/2 65 mm**

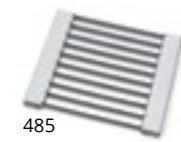

485



| REF   | TIPO / TYPE | CORTE / CUT<br>COUPE / SCHNITT<br>mm | CUCHILLAS / BLADES /<br>LAMES / MESSER | €/u    | 📦 |
|---|-------------|--------------------------------------|--|--------|---|
| <b>SACACORAZONES / CORE / ÉVIDOIR / ENTKERNER</b> |             |                                      |  |        |   |
| 403NH   |             | 6,4                                  | 28                                     | 746,55 | 1 |

\*Y 33,6 cm H 50,8 cm Abierto / Open / Ouvert / Offen  
 \*Y 55,7 cm H 23,3 cm Cerrado / Closed / Fermé / Geschlossen

**Sólo cuchilla de reemplazo / Replacement blade only /**  
**Lame de rechange seule / Nur ersatzmesser**

| REF   | TIPO / TYPE | CORTE / CUT<br>COUPE / SCHNITT<br>mm | CUCHILLAS / BLADES /<br>LAMES / MESSER | €/u    | 📦 |
|---|-------------|--------------------------------------|--|--------|---|
| <b>SACACORAZONES / CORE / ÉVIDOIR / ENTKERNER</b> |             |                                      |  |        |   |
| 485   |             | 6,4                                  | 28                                     | 107,95 | 1 |

**Área de corte completa de 12,7 cm para frutas grandes.**  
 Full 12.7 cm cutting area optimal for large fruits.  
 Longueur de coupe de 13 cm optimale pour les fruits volumineux.  
 Großer 12,5-cm-Schneidbereich eignet sich optimal für große Obstsorten.

**No oscurece la fruta durante el corte, reduciendo así los desechos.**  
 Prevents bruising of fruit during cutting, reducing food waste.  
 N'abîme pas le fruit durant la coupe, réduisant le gaspillage.  
 Verhindert Quetschverletzungen am Obst beim Schneiden und reduziert die Verschwendung.

**500N** Cortador de cebollas / Onion cutter / Coupe-onions / Zwiebelschneider



**ONION KING®**

**Adaptable a /**  
**Adjustable to /**  
**Adaptable à /**  
**Geeignet für (max)**  
**1/1 65 mm**  
**1/2 65 mm**  
**1/3 100 mm**  
**1/4 100 mm**  
**1/6 100 mm**



P510  
13 x 6 cm

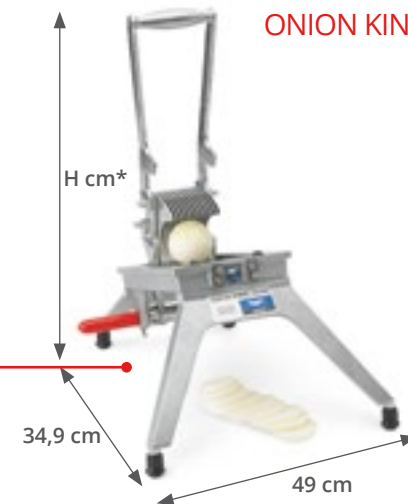

| REF   | TIPO / TYPE | CORTE / CUT<br>COUPE / SCHNITT<br>mm | CUCHILLAS / BLADES /<br>LAMES / MESSER | €/u    | 📦 |
|---|-------------|--------------------------------------|--|--------|---|
| <b>SACACORAZONES / CORE / ÉVIDOIR / ENTKERNER</b> |             |                                      |  |        |   |
| 500N  |             | 4,8                                  | 13                                     | 617,15 | 1 |
| 501N  |             | 6,4                                  | 11                                     | 555,85 | 1 |

\*H 49 cm Abierto / Open / Ouvert / Offen  
 \*H 39,4 cm Cerrado / Closed / Fermé / Geschlossen

**Conjunto de cuchillas / Blade assembly /**  
**Jeu de lames / Messereinheit**

| REF | PARA / FOR /<br>POUR / FÜR | CORTE / CUT<br>COUPE / SCHNITT<br>mm | CUCHILLAS /<br>BLADES /<br>LAMES / MESSER | €/u   | 📦 |
|-----|----------------------------|--------------------------------------|---|-------|---|
| 509 | 500N                       | 4,8                                  | 13  | 71,85 | 1 |
| 511 | 501N                       | 6,4                                  | 11  | 68,90 | 1 |

**Espesor de rebanada exacto / Exact slice thickness.**  
 Épaisseur de tranches exacte / Exakte Scheibendicke.

**2,5X Más rápido / Faster**



**15604** Cortador cebollas en flor / Bloom onion cutter / Coupe onion en fleur / Zwiebelschneider in Blumenform



**INSTABLOOM® II**



15601



| REF   | SECCIONES / SECTION /<br>QUARTIERS / STÜCK | €/u      | 📦 |
|-------|--|----------|---|
| 15604 | 24   | 1.258,60 | 1 |

\*H 76,2 cm Abierto / Open / Ouvert / Offen  
 \*H 48,3 cm Cerrado / Closed / Fermé / Geschlossen

**Conjunto de cuchillas / Blade assembly /**  
**Jeu de lames / Messereinheit**

| REF   | SECCIONES / SECTION /<br>QUARTIERS / STÜCK | €/u    | 📦 |
|-------|--|--------|---|
| 15601 | 24   | 149,85 | 1 |

**Fabricación de aluminio moldeado altamente resistente.**  
 Constructed from heavy duty cast aluminum.  
 En aluminium coulé ultra-robuste.  
 Aus stark belastbarem Aluminiumguss.

**Tiene cuchillas de acero inoxidable con bordes de precisión.**  
 Features precision edged stainless steel blades.  
 Lames inox de précision.  
 Mit präzisionsgefertigten Edeltahlmessern.

**Con ventosas de agarre en la base.**  
 With suction cup base.  
 Avec ventouse d'accrochement à la base.  
 Mit Saugfüßen.



**606N** Cortador seccionador de tomates y cítricos / *Tomato and lemon wedger /*  
 Diviseur à tomates et agrumes / *Wedger Schneider*



**WEDGEMASTER™**

| REF  | SECCIONES / SECTION / QUARTIERS / STÜCK | SE VENDE CON CUCHILLAS / SHIPS WITH BLADES / DESCRIPTION DE LA COUPE / MESSER IM LIEFERUMFANG ENTHALTEN | €/u    | 📦 |
|------|---|---|--------|---|
| 606N | 6                                       | P306/P336   | 273,40 | 1 |
| 808N | 8                                       | P308/P338   | 273,40 | 1 |

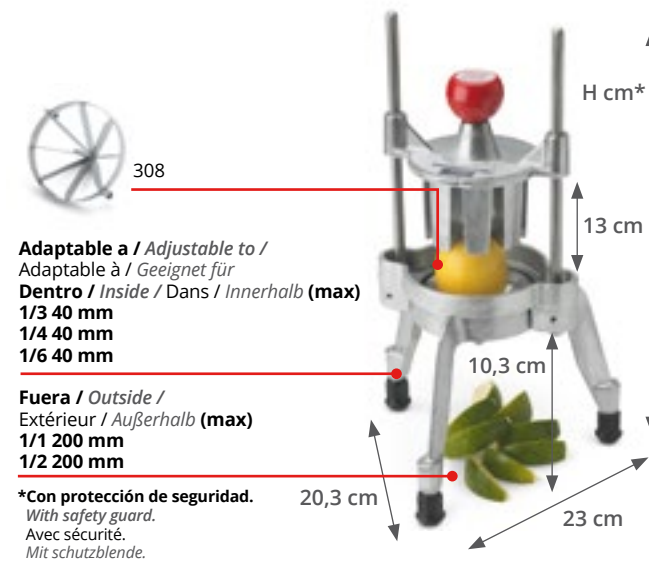

**Conjunto de cuchillas / Blade assembly /**  
**Jeu de lames / Messereinheit**

| REF  | TIPO / TYPE | SECCIONES / SECTION / QUARTIERS / STÜCK | €/u   | 📦 |
|--|-------------|---|-------|---|
| <b>GAJOS / WEDGE / QUARTIERS / ZERTEILER</b> |             |   |       |   |
| 306  |             | 6                                       | 49,10 | 1 |
| 308  |             | 8                                       | 52,40 | 1 |

\*H 40,6 cm **Abierto / Open / Ouvert / Offen**  
 \*H 40,3 cm **Cerrado / Closed / Fermé / Geschlossen**

**3X Más rápido / Faster**



**700-1** Cortador seccionador de tomates y cítricos / *Tomato and lemon wedger /*  
 Diviseur à tomates et agrumes / *Wedger Schneider*



**WEDGEMASTER™ II**

| REF   | TIPO / TYPE | SECCIONES / SECTION / QUARTIERS / STÜCK | €/u    | 📦 |
|-------|-------------|---|--------|---|
| 700-1 |             | 6                                       | 208,20 | 1 |
| 700-4 |             | 8                                       | 225,65 | 1 |

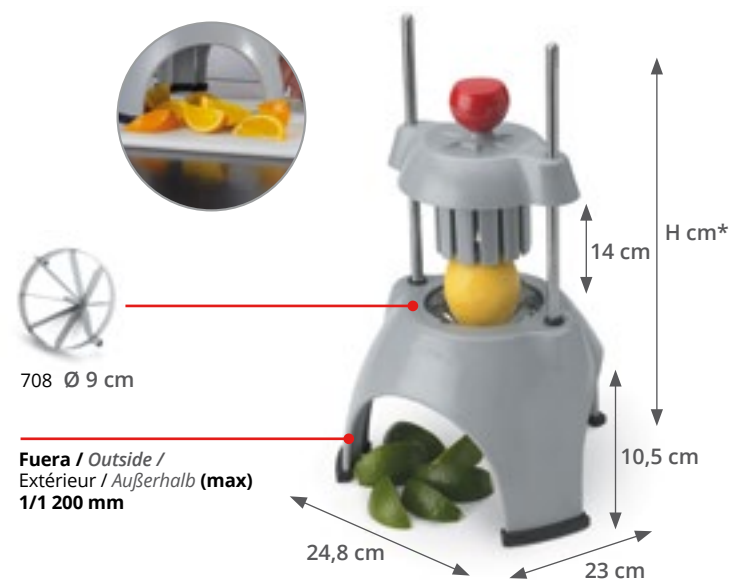

**Conjunto de cuchillas / Blade assembly /**  
**Jeu de lames / Messereinheit**

| REF  | TIPO / TYPE | SECCIONES / SECTION / QUARTIERS / STÜCK | €/u   | 📦 |
|--|-------------|---|-------|---|
| <b>GAJOS / WEDGE / QUARTIERS / ZERTEILER</b> |             |   |       |   |
| 704  |             | 4                                       | 49,35 | 1 |
| 706  |             | 6                                       | 48,80 | 1 |
| 708  |             | 8                                       | 50,15 | 1 |
| 712  |             | 12                                      | 51,15 | 1 |

\*H 40,6 cm **Abierto / Open / Ouvert / Offen**  
 \*H 38,7 cm **Cerrado / Closed / Fermé / Geschlossen**

**Fabricación de material de policarbonato para lavavajillas.**  
*Constructed of dishwasher safe polycarbonate material.*  
*En polycarbonate qui passe au lave-vaisselle.*  
*Aus spülmaschinenfestem Polycarbonatmaterial hergestellt.*

**Compatible / Kompatibel**



**3X Más rápido / Faster**



**P937** Máquina multi-usos / *Versatil machine /* Machine universel / *Universelle Maschine*

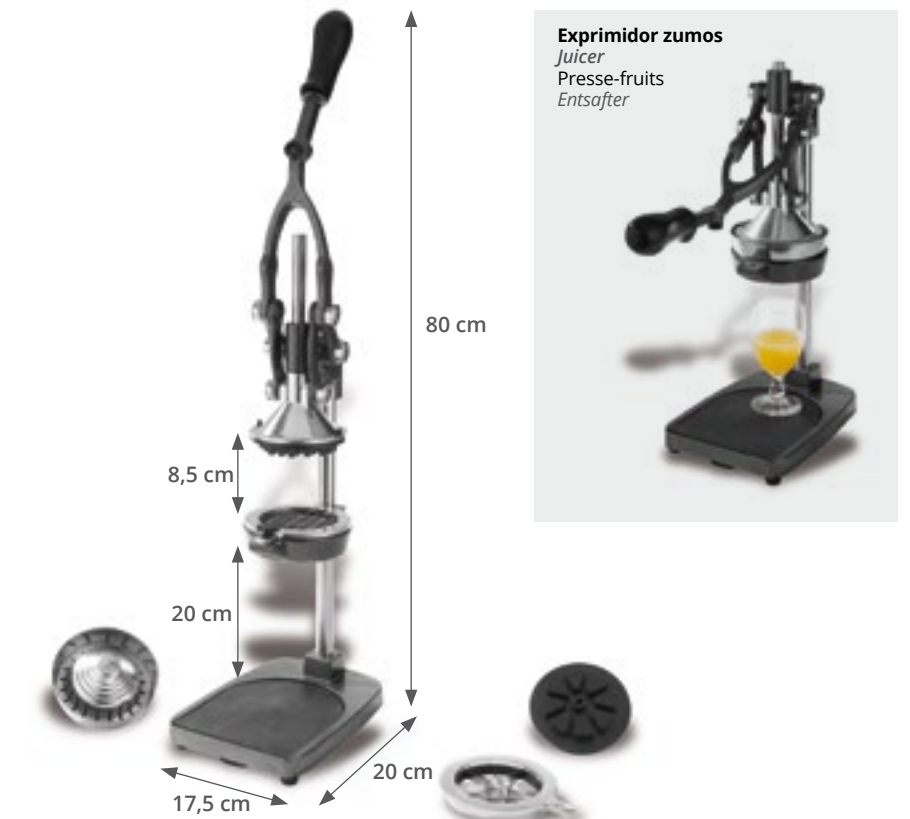

| REF      | H cm | €/u    | 📦 |
|----------|------|--------|---|
| P937.000 | 80   | 135,20 | 1 |

| REF       | H cm | €/u   | 📦 |
|-----------|------|-------|---|
| RE937.001 |      | 17,20 | 1 |
| RE937.002 |      | 17,20 | 1 |
| RE937.003 |      | 17,20 | 1 |

**1811** Cortador en cubos / *Cube cutter /* Coupe en cubes / *Würfelschneider*

**NSF CUBEKING™**

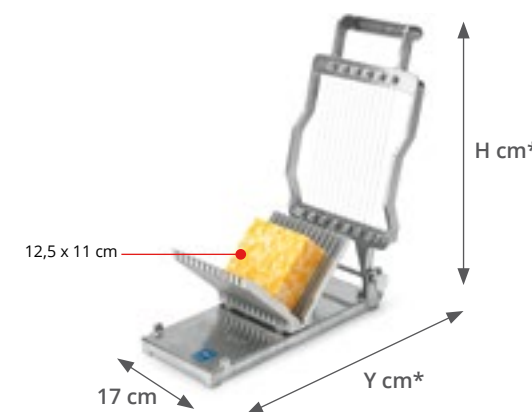

| REF  | CORTE / CUT COUPE / SCHNITT mm | €/u    | 📦 |
|------|--------------------------------|--------|---|
| 1811 | 19,1                           | 304,20 | 1 |
| 1812 | 9,5                            | 308,95 | 1 |

\*Y 33 cm \*H 34 cm **Abierto / Open / Ouvert / Offen**  
 \*Y 32 cm \*H 11 cm **Cerrado / Closed / Fermé / Geschlossen**

**Juego de alambres de repuesto / Replacement wire kit /**  
**Kit de fil de rechange / Draht-ersatzkit**

| REF  | €/u   | 📦 |
|------|-------|---|
| 1823 | 62,90 | 1 |

**Produce cubos, palillos y bloques cuadrados o rectangulares de queso.**  
*Produce uniform cheese cubes, sticks, and square or rectangular blocks.*  
*Produisez des dés, bâtonnets et blocs carrés ou rectangulaires de fromage.*  
*Erzeugen Sie einheitlich große Käsewürfel, Stäbchen und quadratische oder rechteckige Blöcke.*



**P9759** Cortador de tomates / Tomatoes slicer / Coupe tomates / Tomatenschneider



| REF       | CORTE / CUT<br>COUPE / SCHNITT<br>mm | cm             | €/u    | 📦 |
|-----------|--------------------------------------|----------------|--------|---|
| P975.900  | 6,4                                  | 39 x 21,5 x 20 | 183,40 | 1 |
| RE975.901 | 6,4                                  | 25 x 6,8       | 50,35  | 1 |

**5X Más rápido / Faster**



RE975.901  
Cuchilla / Blade / Lame / Klingen

**0643N** Cortador de tomates / Tomatoes slicer / Coupe tomates / Tomatenschneider

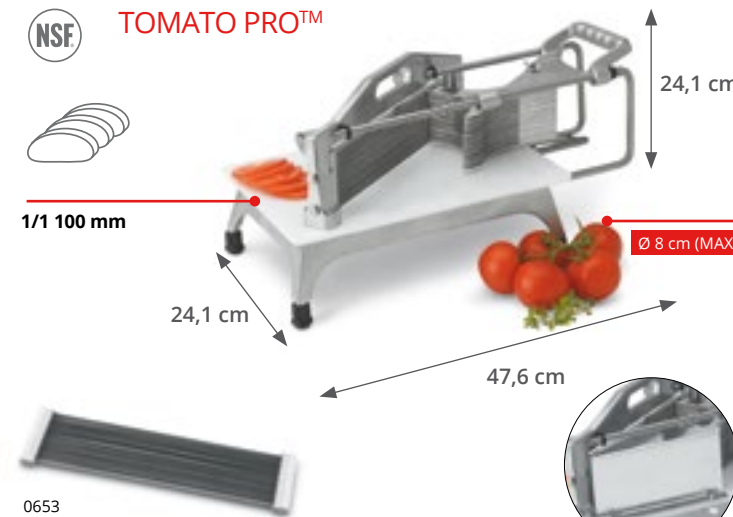

| REF        | CORTE / CUT<br>COUPE / SCHNITT<br>mm | CUCHILLAS / BLADES /<br>LAMES / MESSER | €/u    | 📦 |
|------------|--------------------------------------|--|--------|---|
| 0644N**    | 6,4                                  | 11                                     | 572,90 | 1 |
| 0644SGN**^ | 6,4                                  | 11                                     | 516,15 | 1 |

Cuchilla de reemplazo / Replacement blade item /  
Lame de recharge / Ersatzmesser

| REF    | CORTE / CUT<br>COUPE / SCHNITT<br>mm | CUCHILLAS / BLADES /<br>LAMES / MESSER | €/u   | 📦 |
|--------|--------------------------------------|--|-------|---|
| *0653  | 4,8                                  | 15                                     | 52,00 | 1 |
| **0654 | 6,4                                  | 11                                     | 53,70 | 1 |

^ Con protección de seguridad. Permite sujeción a la mesa.  
With safety guard. Holds firmly on countertop.  
Avec sécurité. Fixation ferme sur la table.  
Mit Schutzblende. Hält fest auf dem Tisch.

**5X Más rápido / Faster**



**15105** Cortador de tomates / Tomatoes slicer / Coupe tomates / Tomatenschneider

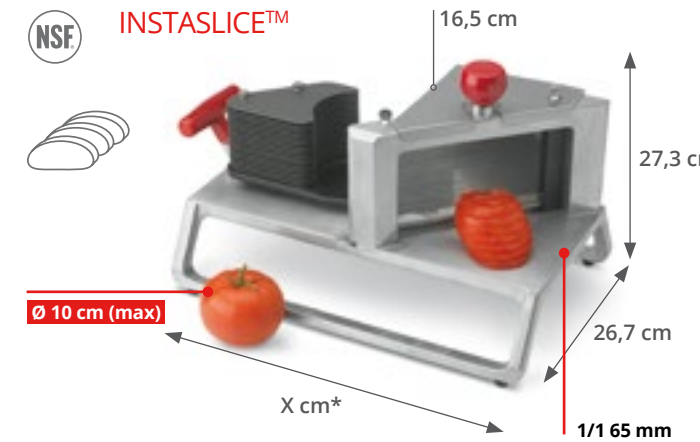

| REF    | TIPO/TYPE | CORTE / CUT<br>COUPE / SCHNITT<br>mm | CUCHILLAS /<br>BLADES /<br>LAMES / MESSER | €/u    | 📦 |
|--------|-----------|--------------------------------------|---|--------|---|
| 15105^ |           | 4,8                                  | 16  | 571,65 | 1 |
| 15103^ |           | 6,4                                  | 12  | 570,85 | 1 |

\*X 44,5 cm Abierto / Open / Ouvert / Offen  
\*X 40,6 cm Cerrado / Closed / Fermé / Geschlossen

Cuchilla de reemplazo / Replacement blade item /  
Lame de recharge / Ersatzmesser

| REF     | TIPO/TYPE | CORTE / CUT<br>COUPE / SCHNITT<br>mm | CUCHILLAS /<br>BLADES /<br>LAMES / MESSER | €/u   | 📦 |
|---------|-----------|--------------------------------------|---|-------|---|
| 15115^  |           | 4,8                                  | 16  | 93,65 | 1 |
| 15209^^ |           | 4,8                                  | 16  | 91,20 | 1 |
| 15113^  |           | 6,4                                  | 12  | 92,45 | 1 |
| 15114^  |           | 9,5                                  | 8   | 93,20 | 1 |

Conjuntos de cuchillas encajables para facilitar el reemplazo.  
"Pop-in pop out" blade assemblies for easy replacement.  
Lames qui s'installent et se sortent par détente pour un remplacement facile.  
Messer lassen sich zum einfachen Auswechseln leicht einsetzen und herausnehmen.

**5X Más rápido / Faster**



Resistente a la corrosión.  
Corrosion resistant.  
Résistant à la corrosion.  
Korrosionsbeständig.

**P9640 Abrelatas industrial acero inoxidable / St/Steel can opener /**  
**Ouvre-boîtes professionnel en acier inoxydable / Industrieller Edelstahl Dosenöffner**



| REF      | H cm | €/u    | 📦 |
|----------|------|--------|---|
| P964.001 | 60   | 131,40 | 1 |

**Cuchilla de recambio / Knife (spare part) /**  
**Couteau (pièce de rechange) / Austauschklinge**

| REF       | €/u   | 📦 |
|-----------|-------|---|
| RE964.100 | 10,00 | 1 |

**Rodillo de recambio / Wheel (spare part) /**  
**Rouleau (pièce de rechange) / Austauschrad**

| REF       | €/u   | 📦 |
|-----------|-------|---|
| RE964.200 | 23,20 | 1 |

55 cm  
**Altura máxima de las latas.**  
*Maximum height of cans.*  
**Hauteur maximale des boîtes.**  
*Maximale Höhe der Dosen.*

**P390 Cortahuevos guitarra de acero inox /**  
**St/Steel egg slicer /**  
**Coupe-oeuf en acier inox /**  
**Eierschneider rostfrei**



| REF      | cm        | €/u   | 📦 |
|----------|-----------|-------|---|
| P390.000 | 7,7 x 9,4 | 12,25 | 1 |

**P3901 Cortahuevos doble uso /**  
**2 way egg cutter /**  
**Coupe-oeuf 2 utilisations /**  
**2 Weg Eierschneider**



| REF      | cm               | €/u   | 📦 |
|----------|------------------|-------|---|
| P390.100 | 11,5 x 9,5 x 3,5 | 11,90 | 1 |

**P610 Cortador y descorazonador manzanas /**  
**Apple cutter & corer /**  
**Vide et coupe pommes /**  
**Apfelschneider und Enthirzer**



**Cuchilla en acero inoxidable y marco en aluminio de fundición**  
*St/Steel blades with cast aluminium frame*  
**Lames inox et manche en aluminium foncé**  
*Messer aus rostfreiem Stahl und Rahmen aus Aluminiumguss*

| REF      | Ø cm | €/u  | 📦 |
|----------|------|------|---|
| P610.000 | 8,5  | 6,50 | 1 |

**P938 Prensa ajos / Garlic Press /**  
**Presse-ail / Knoblauchpresse**



**Aluminio fundición**  
*Cast aluminium*  
**Fonté d'aluminium**  
*Aluminiumguss*

| REF      | €/u  | 📦 |
|----------|------|---|
| P938.000 | 7,55 | 1 |

**P9755 Mandolina corte "V" / "V" shaped mandoline slicer /**  
**"V" mandoline / "V" Gemüsehobel**

**PLÁSTICO / PLASTIC /**  
**PLASTIQUE / PLASTIK**

| REF      | CORTE / CUT<br>COUPE / SCHNITT<br>mm | CUCHILLAS / BLADES /<br>LAMES / MESSER | €/u   | 📦 |
|----------|--------------------------------------|--|-------|---|
| P975.500 | 4 / 7                                | 24 / 12                                | 32,10 | 1 |

**Incluye: 2 cuchillas + 3 guías plástico grosor (1 mm / 2 mm / 3 mm) /**  
**Includes: 2 julienne blades + 3 thickness guides (1 mm / 2 mm / 3 mm) /**  
**Comprend: 2 lames julienne + 3 guides épaisseur (1 mm / 2 mm / 3 mm) /**  
**Inklusive: 2 Klängen + 3 Schneideplatten (1 mm / 2 mm / 3 mm)**

**Pies goma antideslizantes.**  
**Non-slip rubber feet.**  
**Pieds en caoutchouc antidérapants.**  
**Rutschfeste GummifüÙe.**

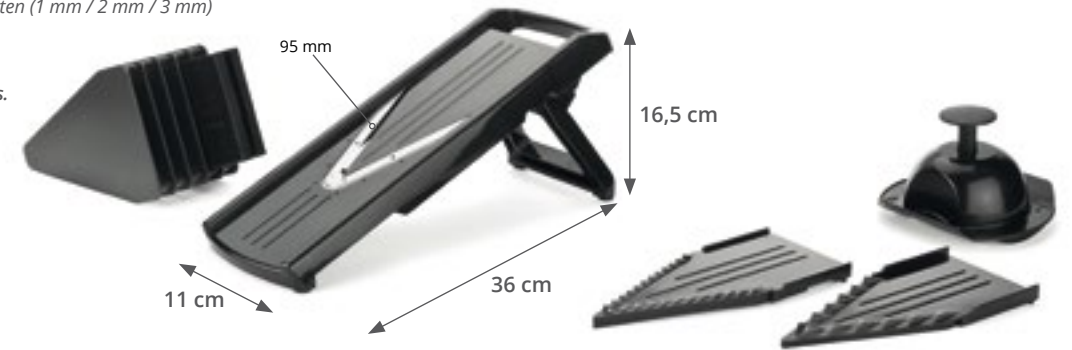

**9756 Mandolina / Mandoline / Mandoline / Mandoline**

**ACERO INOXIDABLE / ST/STEEL /**  
**ACIER INOXYDABLE / ROSTFREIER STAHL**

| REF      | CORTE / CUT<br>COUPE / SCHNITT<br>mm | CUCHILLAS / BLADES /<br>LAMES / MESSER | €/u   | 📦 |
|----------|--------------------------------------|--|-------|---|
| P975.600 | 4 / 9                                | 23 / 11                                | 90,50 | 1 |

**Incluye: cuchilla giratoria + regulador de espesor corte (3, 6 y 9 mm) /**  
**Includes: rotating blades + thickness regulator (3, 6 and 9 mm) /**  
**Comprend: lames tournantes + régulateur épaisseur (3, 6 et 9 mm) /**  
**Inklusiv: drehbare Klinge + Breitenregulierer (3, 6 und 9 mm)**

**Rebanada, rebanada ondulada y bastoncillos.**  
**Slice, wavy slice and sticks.**  
**Tranches, ondulé tranches et bâtonnets.**  
**Scheib, crinkle scheid und stäbchen.**

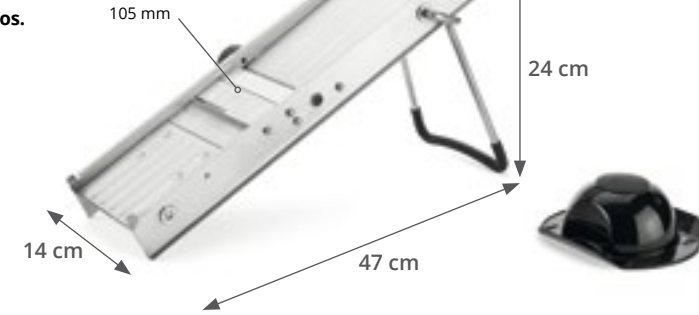

**1400 Descorazonador de tomates / Tomato corer /**  
**Permet d'ôter le coeur de la tomate / Tomatenentkerner**

**TOMATO KING®**



| REF  | €/u  | 📦   |
|------|------|-----|
| 1400 | 2,60 | 144 |

**Dientes de acero inoxidable.**  
**Stainless steel teeth.**  
**Dents en inox.**  
**Edelstahlzähne.**

**Paquete a granel /**  
**Bulk pack /**  
**Paquet en vrac /**  
**GroÙpackung**

**15149 Gel lubricante sanitario / Sanitary gel lubricant /**  
**Gel lubrifiant sanitaire / Medizinisches Gleitgel**

**PETROL GEL**



| REF   | ml  | €/u   | 📦 |
|-------|-----|-------|---|
| 15149 | 118 | 18,40 | 1 |



**PESCADO CRUDO**  
RAW FISH  
POISSON CRU  
ROHER FISCH



**CARNE CRUDA**  
RAW MEAT  
VIANDE CRU  
ROHES FLEISCH



**CARNE CRUDA DE AVE**  
RAW POULTRY & CHIKEN  
VIANDE CRU ET VOLAILLES  
ROHES GEFLÜGEL



**ANTIALÉRGICO**  
ALLERGEN-FREE  
ANTI ALLERGIQUE  
ANTI ALLERGIE



**PAN Y LÁCTEOS**  
BAKERY & DAIRY  
PAIN ET PRODUITS LAITIERS  
BROT UND MILCHPRODUKTE



**CARNE GUISADA**  
COOKED MEAT  
VIANDE CUISINÉE  
GEKOCHTES FLEISCH



**FRUTA Y VEGETALES**  
FRUIT & VEGETABLES  
FRUIT ET LÉGUMES  
OBST & GEMÜSE



**PRESENTACIÓN**  
PRESENTATION  
PRÉSENTATION  
PRÄSENTATION

Presentamos una nueva gama de tablas de corte con más de 20 modelos distintos y más de 100 referencias, concebidas para satisfacer todas las necesidades del mercado. Ofrecemos también la posibilidad de fabricar medidas y grosores especiales sobre pedido. La nueva gama de tablas de corte se presenta en dos modalidades; unas fabricadas en Polietileno (PE) por inyección y la gama más extensa en Polietileno 500 alta densidad (HD PE 500) por termocompresión.

We introduce here with the new range of cutting board with more than 20 different patterns and more than 100 references conceived to fulfill all the market needs. We also offer the possibility to produce special sizes and thicknesses upon request. This new range of cutting boards is presented in two different materials, one made of Polyethylene (PE) using the injection technique and the widest range on High Density Polyethylene 500 (HD PE 500) through thermo compression.

Nous présentons une nouvelle gamme de planches à découper avec plus de 20 modèles différents et plus de 100 références, conçues pour satisfaire tous les besoins du marché. Nous offrons aussi la possibilité de fabriquer des planques avec des mesures et des épaisseurs spéciales sur commande. Cette nouvelle gamme de planches à découper se présentent en deux matériaux différents: certaines sont produites en Polyéthylène (PE) par injection et la majorité de la gamme est produite en Polyéthylène 500 de haute densité (HD PE 500) par thermo compression.

Wir präsentieren eine neue Produktreihe von Schneidbrettern mit mehr als 20 verschiedenen Modellen und über 100 Artikel, um die Bedürfnisse des markts zufrieden zu stellen. Wir bieten auch die Möglichkeit spezielle Masse und Dicke herzustellen abhängig von der Bestellung, die neue Produktreihe bieten wir in zwei verschiedenen varianten an: Eine Variante hergestellt aus Polyethylen (PE) durch Spritzverfahren und die breiteste Produktvariante hergestellt aus Polyethylen 500 hohe dichte (HD PE 500) durch Wärmedruckverfahren.

HD PE  
500

**CARACTERÍSTICAS PRINCIPALES**

Las tablas de corte fabricadas en Polietileno 500 alta densidad, se caracterizan por un alto peso molecular (HMWPE) ofreciendo:

- Alta DURABILIDAD
- 25% más resistencia a la ABRASIÓN.
- Mayor temperatura de fusión: 135,4 °C.
- Temperatura de reblandecimiento: 83 °C
- Mayor RIGIDEZ

\* No presentan deformación durante el aclarado del ciclo de lavado en lavavajillas industriales (temp. máx. aprox. 80 °C).

Conforme a las normativas siguientes: RD 1712/91 registro sanitario de alimentos CE 1935/2004.

**MAIN FEATURES**

The cutting boards made of High Density Polyethylene 500 have higher molecular weight (HMWPE), offering the following properties:

- High DURABILITY
- 25% more resistance to ABRASION
- Higher Fusion temperature: 135,4 °C
- Softening temperature: 83 °C
- Extraordinary RIGIDNESS

\* Do not present deformation during the rinsing process of industrial dishwasher cleaning cycle (max. temp. aprox. 80 °C).

Following the CE 1935/2004 regulation.

**CARACTÉRISTIQUES PRINCIPALES**

Les planches à découper fabriquées en Polyéthylène 500 haute densité ont un poids moléculaire (HMWPE) plus grand qui offre les suivantes propriétés:

- Longue DURÉE
- 25% plus résistant à l'ABRASION
- Température de fusion: 135,4 °C
- Température de ramolissement: 83 °C
- RIGIDITÉ maximale

\* Ne présente pas de déformation lors du cycle lavage dans le lave-vaisselles industriel (Temp. max. aprox. 80 °C).

Conforme à la réglementation 1935/2004.

**HAUPTEIGENSCHAFTEN**

Die Schneidbretter hergestellt aus Polyethylen 500 hohe Dichte haben ein höheres Molekulargewicht (HMWPE), mit folgenden Eigenschaften:

- Hohe LANGLEBIGKEIT
- 25% höherer Verschleisswiderstand
- Höhere Schmelztemperatur: 135,4 °C
- Erweichungstemperatur: 83 °C
- Extrahohe Starrheit

\* Es treten keine Verformungen beim Spülvorgang in industriellen Spülmaschinen auf(max. Temp. ca. 80 °C).

Entsprechend der Norm CE 1935/2004.

**P9118**

300 x 200 x 20



**Con pies silicona**  
With silicon feet  
Avec pieds en silicone  
Mit Silikonfüssen

| REF      | Color  | mm        | H mm | €/u   | 📦 |
|----------|--------|-----------|------|-------|---|
| P911.801 | White  | 300 x 200 | 20   | 11,80 | 1 |
| P911.802 | Red    | 300 x 200 | 20   | 12,50 | 1 |
| P911.803 | Blue   | 300 x 200 | 20   | 12,50 | 1 |
| P911.804 | Yellow | 300 x 200 | 20   | 12,50 | 1 |
| P911.805 | Green  | 300 x 200 | 20   | 12,50 | 1 |
| P911.806 | Brown  | 300 x 200 | 20   | 12,50 | 1 |
| P911.808 | Black  | 300 x 200 | 20   | 12,50 | 1 |

**P9112**



**Con pies silicona**  
With silicon feet  
Avec pieds en silicone  
Mit Silikonfüssen

| REF      | Color | mm        | H mm | €/u   | 📦 |
|----------|-------|-----------|------|-------|---|
| P911.201 | White | 400 x 300 | 20   | 22,90 | 1 |
| P911.202 | White | 600 x 400 | 20   | 40,70 | 1 |

**P9120**

400 x 200 x 20



**Con pies silicona**  
With silicon feet  
Avec pieds en silicone  
Mit Silikonfüssen

| REF      | Color | mm        | H mm | €/u   | 📦 |
|----------|-------|-----------|------|-------|---|
| P912.001 | White | 400 x 200 | 20   | 15,75 | 1 |

**P9113 GN 1/1**



**Con ranura**  
With groove  
Avec rigole  
Mit Fuge

**Con pies silicona**  
With silicon feet  
Avec pieds en silicone  
Mit Silikonfüssen

| REF      | Color  | mm        | H mm | €/u   | 📦 |
|----------|--------|-----------|------|-------|---|
| P911.301 | White  | 530 x 325 | 20   | 31,35 | 1 |
| P911.302 | Red    | 530 x 325 | 20   | 31,35 | 1 |
| P911.303 | Blue   | 530 x 325 | 20   | 31,35 | 1 |
| P911.304 | Yellow | 530 x 325 | 20   | 31,35 | 1 |
| P911.305 | Green  | 530 x 325 | 20   | 31,35 | 1 |
| P911.306 | Brown  | 530 x 325 | 20   | 31,35 | 1 |

**P9117 GN 1/2**

320 x 265 x 20



**Con pies silicona**  
With silicon feet  
Avec pieds en silicone  
Mit Silikonfüssen

| REF      | Color | mm        | H mm | €/u   | 📦 |
|----------|-------|-----------|------|-------|---|
| P911.701 | White | 320 x 265 | 20   | 16,50 | 1 |

**P9114**

400 x 300 x 20



**Con pies silicona**  
With silicon feet  
Avec pieds en silicone  
Mit Silikonfüssen

| REF      | Color  | mm        | H mm | €/u   | 📦 |
|----------|--------|-----------|------|-------|---|
| P911.401 | White  | 400 x 300 | 20   | 23,75 | 1 |
| P911.402 | Red    | 400 x 300 | 20   | 24,90 | 1 |
| P911.403 | Blue   | 400 x 300 | 20   | 24,90 | 1 |
| P911.404 | Yellow | 400 x 300 | 20   | 24,90 | 1 |
| P911.405 | Green  | 400 x 300 | 20   | 24,90 | 1 |
| P911.406 | Brown  | 400 x 300 | 20   | 24,90 | 1 |
| P911.408 | Black  | 400 x 300 | 20   | 24,90 | 1 |

Ver productos en / See products on / Voir produits en page / Siehe produkte in

P. 200

**SOPORTE PARA TAPAS GN /**  
STAND FOR GN LIDS /  
SUPPORT POUR COUVERCLES GN /  
STÄNDER FÜR GN DECKEL



## 5.3 UTENSILIOS DE COCINA / KITCHEN UTENSILS / USTENSILES DE CUISINE / KÜCHENUTENSILIEN

### TABLAS DE CORTE / CUTTING BOARDS / PLANCHES À DÉCOUPER / SCHNEIDBRETTER

#### P9119

500 x 300 x 20



**Con pies silicona**  
With silicon feet  
Avec pieds en silicone  
Mit Silikonfüßen

| REF      | Color  | mm        | H mm | €/u   | 📦 |
|----------|--------|-----------|------|-------|---|
| P911.901 | White  | 500 x 300 | 20   | 29,75 | 1 |
| P911.902 | Red    | 500 x 300 | 20   | 31,15 | 1 |
| P911.903 | Blue   | 500 x 300 | 20   | 31,15 | 1 |
| P911.904 | Yellow | 500 x 300 | 20   | 31,15 | 1 |
| P911.905 | Green  | 500 x 300 | 20   | 31,15 | 1 |
| P911.906 | Brown  | 500 x 300 | 20   | 31,15 | 1 |
| P911.908 | Black  | 500 x 300 | 20   | 31,15 | 1 |

#### P9116

600 x 400 x 20



**Con pies silicona**  
With silicon feet  
Avec pieds en silicone  
Mit Silikonfüßen

| REF      | Color  | mm        | H mm | €/u   | 📦 |
|----------|--------|-----------|------|-------|---|
| P911.601 | White  | 600 x 400 | 20   | 47,50 | 1 |
| P911.602 | Red    | 600 x 400 | 20   | 49,85 | 1 |
| P911.603 | Blue   | 600 x 400 | 20   | 49,85 | 1 |
| P911.604 | Yellow | 600 x 400 | 20   | 49,85 | 1 |
| P911.605 | Green  | 600 x 400 | 20   | 49,85 | 1 |
| P911.606 | Brown  | 600 x 400 | 20   | 49,85 | 1 |
| P911.608 | Black  | 600 x 400 | 20   | 49,85 | 1 |

#### P9130 Mesa de corte / Cutting board table / Table de découpe / Schneidstisch



**Con ranura**  
With groove  
Avec rigole  
Mit Fuge

**No incluye contenedor Gastronorm**  
Delivered without the GN container  
Livré sans le bac GN  
Ausschliesslich GN Behälter

**Para almacenar alimentos recién cortados en cubeta GN 1/3**  
Perfect for storing direct cut products into a 1/3 GN pan  
Permet découper les produits directement au dessus du bac Gastronorme 1/3  
Für die Aufbewahrung von frischgeschnittenen Lebensmitteln im Behälter GN 1/3

| REF      | Color | mm        | H mm | €/u   | 📦 |
|----------|-------|-----------|------|-------|---|
| P913.000 | White | 650 x 400 | 110  | 91,45 | 1 |

#### P9115 GN 1/1

530 x 325 x 20



**Con pies silicona**  
With silicon feet  
Avec pieds en silicone  
Mit Silikonfüßen

| REF      | Color  | mm        | H mm | €/u   | 📦 |
|----------|--------|-----------|------|-------|---|
| P911.501 | White  | 530 x 325 | 20   | 34,10 | 1 |
| P911.502 | Red    | 530 x 325 | 20   | 35,80 | 1 |
| P911.503 | Blue   | 530 x 325 | 20   | 35,80 | 1 |
| P911.504 | Yellow | 530 x 325 | 20   | 35,80 | 1 |
| P911.505 | Green  | 530 x 325 | 20   | 35,80 | 1 |
| P911.506 | Brown  | 530 x 325 | 20   | 35,80 | 1 |
| P911.508 | Black  | 530 x 325 | 20   | 35,80 | 1 |

#### P9135 Bar



**Sin pies**  
Without feet  
Sans pieds  
Ohne Füße

| REF      | Color | mm        | H mm | €/u   | 📦 |
|----------|-------|-----------|------|-------|---|
| P913.501 | White | 160 x 250 | 10   | 5,75  | 1 |
| P913.601 | White | 250 x 200 | 10   | 7,20  | 1 |
| P913.701 | White | 300 x 200 | 10   | 8,60  | 1 |
| P913.901 | White | 320 x 240 | 10   | 10,95 | 1 |

#### P911407 Tabla de corte / Cutting Board / Planche à découper / Schneidbretter



**Con pies silicona**  
With silicon feet  
Avec pieds en silicone  
Mit Silikonfüßen

| REF      | mm              | H mm | €/u   | 📦 |
|----------|-----------------|------|-------|---|
| P911.407 | 400 x 300       | 20   | 24,90 | 1 |
| P911.507 | 530 x 325 (1/1) | 20   | 35,80 | 1 |
| P911.607 | 600 x 400       | 20   | 49,85 | 1 |

#### P901 Recogeverduras inox / St/Steel vegetable picker / Pelle à légumes inox / Gemüsehacker rostfrei



| REF      | cm      | €/u  | 📦 |
|----------|---------|------|---|
| P901.014 | 14 x 10 | 8,95 | 1 |
| P901.018 | 18 x 12 | 9,75 | 1 |





**P609 Balanza digital / Electronic scale /**  
Balance électronique / Digitale Waage



Cable de alimentación no incluido. Funciona con pilas /  
Power cable not included. Battery powered /  
Câble d'alimentation non inclus. Fonctionne avec des piles /  
Stromkabel nicht enthalten. Batteriebetrieben.

| REF      | kg | Grs | €/u    | 📦 |
|----------|----|-----|--------|---|
| P609.010 | 10 | 2   | 119,45 | 1 |

**P6092 Balanza digital / Digital kitchen scale /**  
Balance électronique / Digitale Waage



Plataforma en acero inoxidable. Pantalla LED. Funciona con pilas /  
Surface made of St/Steel. LED Display. Battery powered /  
Plateau fabriquée en acier inoxydable. Scran LED. Fonctionne avec des piles /  
Plattform rostfrei. LED Display. Batteriebetrieben.

| REF      | kg | d (g) | €/u   | 📦 |
|----------|----|-------|-------|---|
| P609.200 | 15 | 1     | 82,00 | 1 |

**P6097 Balanza electrónica / Electronic kitchen scale /**  
Balance électronique / Elektronische Waage



| REF      | kg | Grs | Plataforma / Surface /<br>Plateau / Plattform<br>Ø cm | €/u   | 📦 |
|----------|----|-----|---|-------|---|
| P609.705 | 5  | 1   | 11  | 18,70 | 1 |

Gran precisión / Multifunción de peso / Contador de piezas / Sistema  
ahorro energía / Bandeja de plástico.

High accuracy / Multi-function weight and counting / Energy-saving system /  
Plastic Platform.

Haut précision / Multi-fonction des poids / Compteur des pièces / Système  
d'économie d'énergie / Plateau en plastique.

Hohe Präzision / Multi-Funktion Wiegen / Stückzähler / Energiesparsystem /  
Plattform Plastik.

**P611 Reloj de cocina digital / Kitchen timer alarm /**  
Minuteur de cuisine / Digitale Küchenuhr



| REF      | cm              | €/u  | 📦 |
|----------|-----------------|------|---|
| P611.000 | 6,8 x 6,8 x 2,5 | 5,70 | 1 |

**P9802 Termómetro de cocción / Cooking thermometer /**  
Thermomètre à cuisson / Kochthermometer



Con protección de plástico / With plastic protection /  
Avec gaine plastique / Mit Plastikschutz.

| REF      | L cm | Temp. max. | €/u   | 📦 |
|----------|------|------------|-------|---|
| P980.200 | 28   | 100 °C     | 20,70 | 1 |

**P9816 Termómetro de cocción / Cooking thermometer /**  
Thermomètre à cuisson / Kochthermometer



Con protección de plástico /  
With plastic protection /  
Avec gaine plastique /  
Mit Plastikschutz

| REF      | L cm | Temp.            | €/u   | 📦 |
|----------|------|------------------|-------|---|
| P981.600 | 17   | -10 °C / +200 °C | 21,55 | 1 |

**P9814 Termómetro digital / Digital thermometer /**  
Thermomètre digital / Digitales Thermometer

Con sonda de acero inoxidable. Protección antisalpicaduras. Con  
pantalla iluminada. La sonda esta sujeta al lateral del  
aparato.

With St/Steel probe. Splash-proof.  
Illuminated display.  
Probe attached to side panel.

Avec sonde inox. Etanche aux éclaboussures.  
Ecran illuminé. La sonde est attachée  
au côté lateral de l'appareil.

Temperaturfühler aus rostfreiem Stahl  
Antispritzschutz. Beleuchtetes Display.  
Seitlicher Fühlerhalter.



| REF      | mm            | Display mm | Temp.            | €/u    | 📦 |
|----------|---------------|------------|------------------|--------|---|
| P981.400 | 135 x 92 x 27 | 42 x 22    | -20 °C / +200 °C | 129,90 | 1 |

**P9800 Termómetro nevera /**  
Cold storage thermometer /  
Thermomètre congélateur /  
Külschrankthermometer



Acabado esmaltado /  
Enameled finish /  
Émaillé /  
Emailierte Ausfertigung

| REF      | L cm | Temp.           | €/u  | 📦 |
|----------|------|-----------------|------|---|
| P980.000 | 28   | -30 °C / +50 °C | 9,95 | 1 |

**P981650 Termómetro bolsillo con protección /**  
Pocket thermometer with protection /  
Thermomètre de poche avec protection /  
Taschenthermometer mit Schutz



| REF      | L cm | Temp.           | €/u  | 📦  |
|----------|------|-----------------|------|----|
| P981.650 | 14,3 | -40 °C / +70 °C | 6,25 | 24 |

**P9815 Termómetro digital de cocción con temporizador /**  
Cooking thermometer with timer /  
Thermomètre à cuisson avec temporisateur /  
Digitales Kochthermometer mit Timer-Funktion

Plástico blanco. Base magnética para  
sujeción en superficies de metal.  
Temperatura/tiempo programable con  
señal de alarma. Sonda de acero inoxidable y cable alambre.

White plastic. Magnetic base for attachment  
on metal surface. Programmable temperature/  
time, with alarm signal. St/Steel probe and  
wire cable.

Plastique blanc. Base magnétique  
pour l'attacher à une surface  
métallique. Température/temps  
programmable avec sonnette  
d'alarme. Sonde inox et filet.

Weisses Plastik. Magnetische Haftung für  
metallische Oberflächen. Temperatur/Zeit  
programmierbar mit Alarm. Rostfreier Fühler  
mit Drahtkabel.



| REF      | L mm sonda + cable | Temp.          | €/u   | 📦 |
|----------|--------------------|----------------|-------|---|
| P981.500 | 90                 | 0 °C / +200 °C | 43,05 | 1 |

**P98005 Termómetro nevera horizontal /**  
Horizontal refrigerator thermometer /  
Thermomètre congélateur horizontal /  
Horizontales Külschrankthermometer



| REF      | mm       | Temp.           | €/u  | 📦  |
|----------|----------|-----------------|------|----|
| P980.050 | 135 x 35 | -40 °C / +20 °C | 9,00 | 24 |

**P9804** Termómetro infrarojos con mira laser / Infrared thermometer with laser pointer /  
Thermomètre infra-rouge a visée laser / Infrarot Thermometer mit Laser Pointer



| REF      | L cm | Temp.            | €/u    |   |
|----------|------|------------------|--------|---|
| P980.400 | 17   | -60 °C / +500 °C | 139,35 | 1 |

**Pantalla LCD**  
LCD Display  
Écran LCD  
LCD Display

**IDEA!** Ideal para medir la temperatura de la superficie de los alimentos, sin contacto.  
Non-contact temperature measure food's surface.  
Ideal pour la mesure de température de surface des aliments, sans contact.  
Ideal für Temperaturmessung von Lebensmittel ohne Berührung.

**P604** Jarra de medidas / Measuring jug /  
Pot mesureur / Messbecher



| REF      | Lts  | €/u   |   |
|----------|------|-------|---|
| P604.001 | 1,00 | 16,55 | 1 |
| P604.002 | 2,00 | 31,70 | 1 |

**P846** Jarra de medidas en polipropileno /  
Polypropylene measuring jug /  
Pot mesureur en polypropylène /  
Messbecher aus Polypropylen



| REF      | Lts  | €/u   |   |
|----------|------|-------|---|
| P846.025 | 0,25 | 3,90  | 1 |
| P846.050 | 0,50 | 4,00  | 1 |
| P846.100 | 1,00 | 6,55  | 1 |
| P846.200 | 2,00 | 11,00 | 1 |
| P846.300 | 3,00 | 13,15 | 1 |

**P6045** Juego 4 cazos de medidas inox /  
St/Steel 4 pcs set measuring cups /  
Set 4 casseroles doseur /  
4 teiliges Messkellenset rostfreies Stahl



| REF      | ml                  | €/u  |    |
|----------|---------------------|------|----|
| P604.500 | 59 - 78 - 118 - 236 | 8,55 | 12 |

**P603** Cubo con base /  
Bucket with base /  
Seau avec base /  
Eimer mit Skalierung

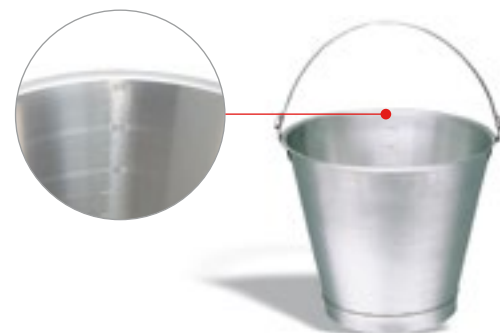

| REF      | Ø cm | H cm  | Lts   | €/u    |   |
|----------|------|-------|-------|--------|---|
| P603.012 | 31,0 | 28,50 | 12,00 | 107,90 | 1 |
| P603.015 | 32,5 | 32,50 | 15,00 | 117,90 | 1 |

**P9473** Guantes protección térmica / Heat protection gloves /  
Gants protection thermique / Hitzehandschuh



Se venden por pares  
Sold in pairs  
Vendues par paires  
Verkauf im Paar

| REF      | Talla / Size / Taille / Grösse | €/u   |   |
|----------|--------------------------------|-------|---|
| P947.302 | M                              | 33,80 | 1 |
| P947.303 | L                              | 34,65 | 1 |

Con recubrimiento de nitrilo exterior y forro algodón interior. Llevan un tratamiento Actifresh y Sanitized que los provee de protección contra los microorganismos los cuales pueden causar malos olores y infecciones.

With an outer nitrile coating and an inner cotton lining. They have an Actifresh and Sanitized treatment that provides protection against micro-organisms which can cause odours and infections.

Avec revêtement extérieur nitrile et doublé coton à l'intérieur. Ils sont traités Actifresh et Sanitized qui les protègent des microorganismes pouvant causer des mauvaises odeurs et des infections.

Mit Nitrilbeschichtung außen und Baumwollfutter innen. Mit Actifresh- und Sanitized-Behandlung zum Schutz gegen Mikroorganismen, die unangenehme Gerüche und Infektionen verursachen können.

**P9477** Manopla silicona con funda algodón / Silicone oven glove with cotton cover /  
Gant silicone à fourreau coton / Silikonhandschuh mit Baumwollfutter



| REF      | L cm | €/u   |   |
|----------|------|-------|---|
| P947.700 | 42,5 | 27,90 | 1 |

**P9474** Manopla Silicona / Silicone oven mitt /  
Moufle en silicone / Silikonbackhandschuh



| REF      | L cm | €/u   |   |
|----------|------|-------|---|
| P947.400 | 30   | 16,90 | 1 |

**P9476** Paño de silicona / Silicone pot-grabber /  
Torchon en silicone / Silikontuch

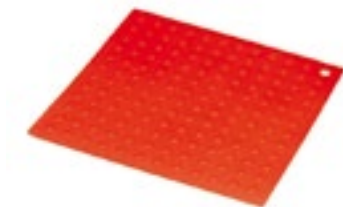

| REF      | cm          | €/u  |   |
|----------|-------------|------|---|
| P947.600 | 17,6 x 17,6 | 5,65 | 1 |

**ALFOMBRAS CAUCHO / NATURAL RUBBER MATS /**  
TAPIS EN CAOUTCHOUC / KAUTSCHUKMATTEN

**P26000** Alfombra / Mat / Tapis / Matte

✓ REACH COMPLIANT

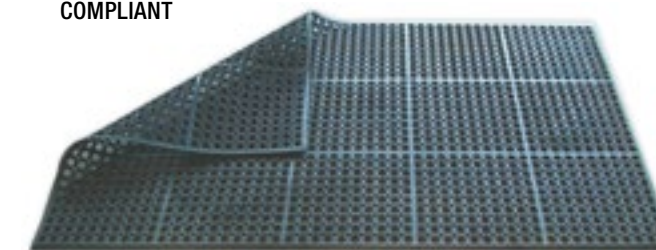

| REF     | cm              | €/u   |   |
|---------|-----------------|-------|---|
| P26.000 | 90 x 150 x 1,20 | 43,15 | 1 |

**P26001** Alfombra / Mat / Tapis / Matte

✓ REACH COMPLIANT

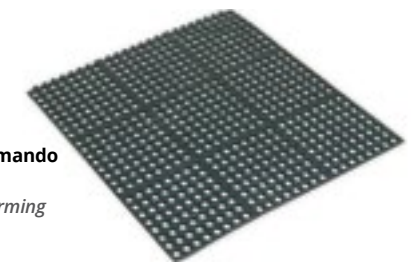

Estas alfombras se pueden conectar unas con otras formando mayores superficies.

You can connect these mats forming bigger surfaces.

Avec système de liaison pour composer une surface plus grande.

Für grössere Flächen kann man diese Matten mit anderen verbinden.

| REF     | cm             | €/u   |   |
|---------|----------------|-------|---|
| P26.001 | 90 x 90 x 1,20 | 25,25 | 1 |